

Service Manual

Microwave Oven

NN-V659WB
NN-V659CB
NN-V659FB
NN-V629MB
NN-V689WB

INVERTER
 SYSTEM INSIDE



Specifications:

Power Source:	240 V AC Single Phase, 50 Hz
Power Requirements:	Microwave: 1280W, Grill: 1360W, Maximum: 2580W
Output: (IEC705-88)	900W
Microwave Frequency:	2,450Mhz
Timer:	99 min. 99 sec.
Oven Cavity Size:	27L
Outside Dimensions:	510mm (W) X 380mm (D) X 304mm (H)
Inside Dimensions:	359mm (W) X 352mm (D) X 217mm (H)
Weight:	13 Kg
Inverter Power Supply	
Output power:	IEC705-88 Test procedure
Specifications subject to change without notice	

Panasonic

© 1999 Matsushita Electric Industrial Co., Ltd.
 All rights reserved. Unauthorized copying and
 distribution is a violation of law.

WARNING

This service information is designed for experienced repair technicians only and is not designed for use by the general public. It does not contain warnings or cautions to advise non-technical individuals of potential dangers in attempting to service a product. Products powered by electricity should be serviced or repaired only by experienced professional technicians. Any attempt to service or repair the product dealt with in this service information by anyone else could result in serious injury or death.

WARNING

* This product should be serviced only by trained, qualified personnel.
 This service manual covers products for following markets.
 When troubleshooting or replacing parts, please refer to the country identifications shown below for your applicable product specification.
 BPQ ... for the United Kingdom

DANGER OF HIGH VOLTAGE AND HIGH TEMPERATURE (HOT/LIVE) OF THE INVERTER POWER SUPPLY(U)

INVERTER WARNING NEW H.V.

This Inverter board looks like a regular PCB, however, this PCB drives the magnetron tube with extremely high voltage and high current.

- IT HAS:**
- 1: Very high voltage and high current circuit.
 It functions the same as the high voltage transformer and high voltage capacitor in ordinary microwave ovens.
 2. aluminium heat sink is very hot.
 3. Very high voltage may remain in the circuitry even when the oven is off. High voltages may remain in the capacitors on the board.

- DO NOT:**
- *1. Do not touch the circuitry as it becomes very hot (high voltage). Even when replacing board, extreme care should be taken to avoid possible electric shock. High voltage may remain in the circuit.
 - *2. Do not touch aluminium heat sink because it is very hot in high voltage and also very hot in high heat energy.
 - *3. Do not try to repair the Inverter PCB as this can be very dangerous. Replace the whole High Voltage Inverter Circuit(U) unit and return fully re-packed with the original shopping box and shipping materials.
 - *4. Do not try to adjust or tamper with the preset volume on the Inverter board because it is very dangerous to adjust it without proper test equipment.
 - *5. Do not test oven while Inverter grounding strip or screws are loose. It is very dangerous to operate the H.V. Inverter Circuit (U) with loose mounting screws or if improperly grounded.

INVERTER POWER SUPPLY DIAGRAM

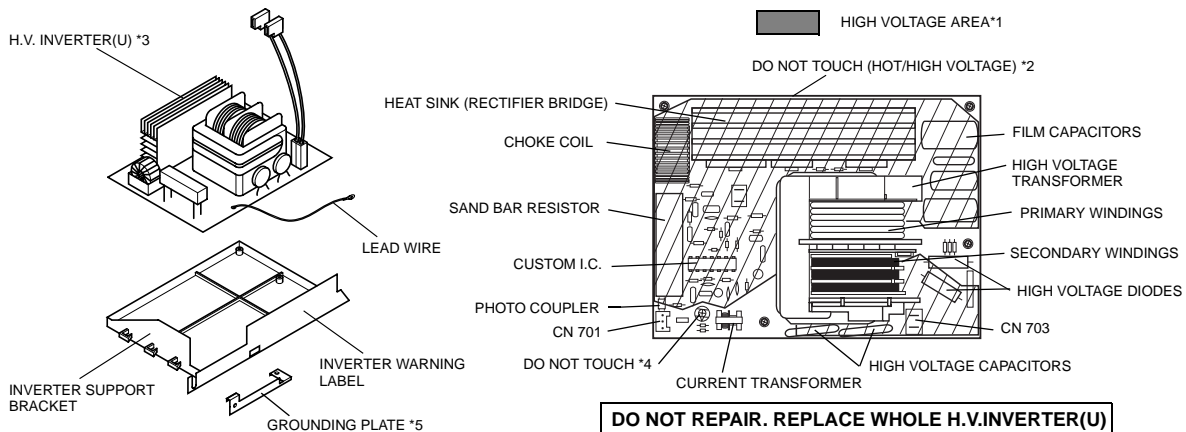

TABLE OF CONTENTS

1. CONTROL PANELS.....	4
2. OPERATION AND DIGITAL PROGRAMMER CIRCUIT TEST PROCEDURE.....	5
3. SCHEMATIC DIAGRAM.....	8
4. DESCRIPTION OF OPERATING SEQUENCE.....	9
4.1 Variable power cooking control.....	9
4.2 Grill cooking.....	9
4.3 Combination cooking.....	9
4.4 Autoweight defrost, autoweight cook.....	9
4.5 Auto Sensor cook NN-V689WB.....	10
5. CAUTIONS TO BE OBSERVED WHEN TROUBLESHOOTING.....	11
5.1 Check the grounding.....	11
5.2 Inverter Warnings.....	11
5.3 When parts must be replaced, remove the power plug from the outlet.....	12
5.4 When the 10A fuse is blown due to the operation of short switch:.....	12
5.5 Avoid inserting nails, wire, etc. through any holes in the unit during operation.....	12
5.6 Confirm after repair.....	12
6. DISASSEMBLY AND PARTS REPLACEMENT PROCEDURE.....	13
6.1 Magnetron.....	13
6.2 Inverter Power Supply(U).....	13
6.3 Digital Programmer Circuit (DPC) and membrane key board.....	14
6.4 Low voltage transformer and/or power relays (RY1).....	14
6.5 Fan Motor.....	14
6.6 Door disassembly.....	15
6.7 Turntable motor.....	15
6.8 Quartz heater.....	15
6.9 Steam Sensor NN-V689WB.....	16
7. COMPONENT TEST PROCEDURE.....	17
7.1 Primary Latch Switch, Secondary (Secondary Latch Switch and Power Relay B) Interlocks.....	17
7.2 Short Switch & Monitor Circuit.....	17
7.3 Magnetron.....	17
7.4 Push button key board.....	17
7.5 Inverter Power Supply (U).....	18
7.6 Inverter Power supply (U).....	18
7.7 Steam Sensor and digital programmer circuit.....	18
8. MEASUREMENTS AND ADJUSTMENTS.....	19
8.1 Installation of Primary latch switch, Secondary latch switch and Short switch.....	19
8.2 Measurement of microwave output.....	19
9. TROUBLESHOOTING GUIDE.....	20
10. EXPLODED VIEW AND PARTS LIST.....	24
11. PARTS LISTS.....	25
12. DOOR ASSEMBLY.....	26
13. ESCUTCHEON BASE ASSEMBLY.....	27
14. PACKING AND ACCESSORIES.....	28
15. TRIM KIT PARTS LIST.....	29
16. DIGITAL PROGRAMMER CIRCUIT.....	30
17. DIGITAL PROGRAMMER CIRCUIT - PARTS LIST.....	32

FEATURE CHART

FEATURES	NN-V659 NN-V629	NN-V689
Microwave	6	6
Grill	3	3
Combination	3x3	3 x 3
Weight Defrost	3	3
Weight Combination	10	-
Stage Cooking	3 stage	3 stage
Delay Stand	Yes	Yes
Clock	12 Hrs	12 Hrs
Word Prompt	English	English
Weight Reheat	2	-
Weight Cook	2	-
Sensor Reheat	-	2
Sensor Cook	-	6
Sensor Combination	-	6

1. CONTROL PANELS

NN-V659*/NN-V629*

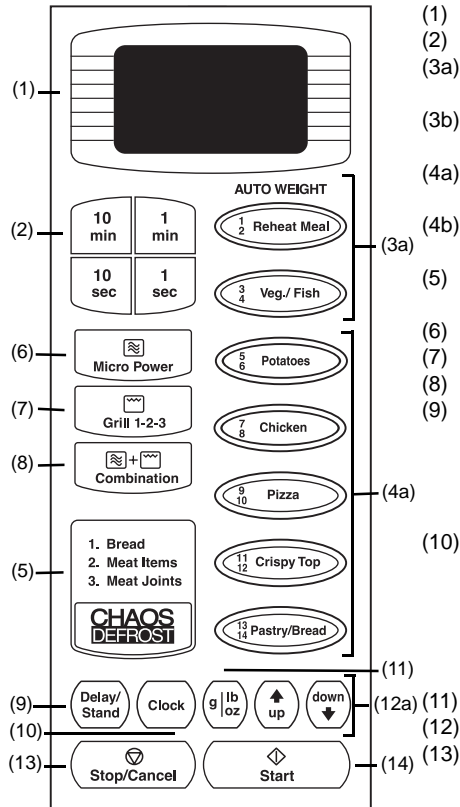

- (1) Display Window
- (2) Time Pads
- (3a) Auto Weight Microwave Programs
- (3b) Auto Sensor Microwave Program
- (4a) Auto Weight Combination Programs
- (4b) Auto Sensor Combination Programs
- (5) Auto Weight Defrost Programs
- (6) Microwave Power Setting
- (7) Grill Setting
- (8) Combination Pad
- (9) Delay/Stand Pad:
This can be used to delay a cooking program for up to 9 hrs 99 mins., or used to time or for standing (non-cooking) time.
- (10) Clock Pad:
Press the clock pad. Using the minute and second pads set the clock (12 hr clock). Press clock pad again to stop colons flashing.
- (11) lb/oz Conversion Pad
- (12) Weight Selection Pads
- (13) Stop/Cancel Pad:
Before Cooking:
One press clears your instructions.
During Cooking:
One press temporarily stops the cooking program. Another press cancels all your instructions and the time of day will appear in the display.
- (14) Start Pad:
Press to start operating the oven. If during cooking the door

NN-V689

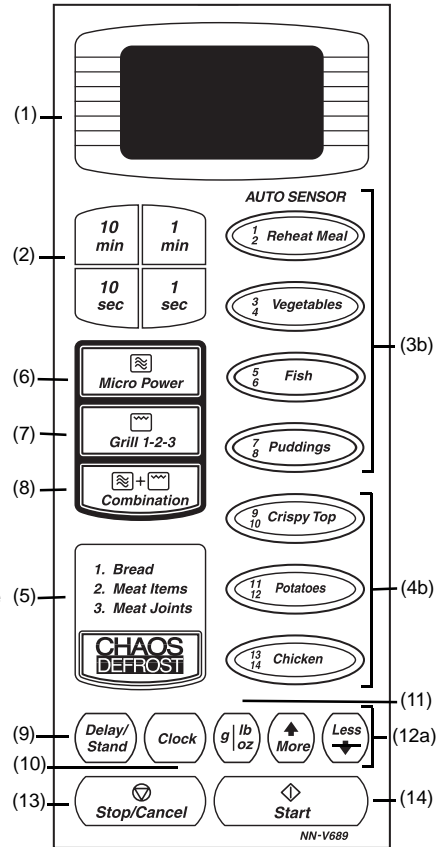

* The design of your control panel may vary from the panel displayed (depending on colour), but the words on the pads will be the same.

Beep Sound

A beep sounds when a pad is pressed. If this beep does not sound, the setting is incorrect. When the oven changes from one function to another, two beeps sound. After completion of cooking, five beeps sound

2. OPERATION AND DIGITAL PROGRAMMER CIRCUIT TEST PROCEDURE

Operation guide on the display.

To assist in programming, the next operation will appear on the display. When you are used to operating the oven, you can turn the operating guide off.

To turn off:

Press 3 times



1. SET CLOCK

OPERATION	DISPLAY
1. Plug the power supply cord into the wall outlet	WELCOME TO PANASONIC. REFER TO OPERATING INSTRUCTIONS
2. Press clock pad 	SET TIME
3. Enter time of day Once— —Once Twice— —5 Times	11 * 25 — — PRESS CLOCK
4. Press clock 	11:25

2. MICROWAVE COOKING - 2 STAGE

OPERATION	DISPLAY
1. Place water load in oven	
2. Press Micro Power once to set High Power 	HIGH SET TIME
3. Set time at 5 sec by pressing 1 sec pad 5 times —5 Times 	5 SEC — — PRESS START HIGH
4. Press Micro Power pad 3 times to set Medium Power 	MEDIUM — — SET TIME
5. Set for 1 minute by pressing 1min pad once —Once 	1 MIN 00 SEC — — PRESS START MEDIUM

To turn on:

Press 3 times







OPERATION	DISPLAY
6. Press start pad 	5 SEC
7. When 1st stage cooking has elapsed oven automatically switches to 2nd stage 	1 MIN 00 SEC
8. When 2nd stage cooking has elapsed oven beeps 5 times and shuts off	OPEN DOOR



3. AUTO WEIGHT DEFROST

OPERATION	DISPLAY
1. Select desired program 	MEAT ITEMS SET WEIGHT **
2. Press g or lb and oz 	LB OZ MEAT ITEMS SET WEIGHT **
3. Enter the weight by pressing up and down pads NN-V689 	1LB OZ PRESS START **
4. Press start pad 	9 MIN 08 SEC **







4. DELAY STAND

OPERATION	DISPLAY
1. Set power level and time	
2. Press stand 	STAND SET TIME
3. Set standing time 	H 1 00 PRESS START
4. Press start 	 1 00 MIN SEC  1 00 MIN SEC















5. DELAY START

OPERATION	DISPLAY
1. Press delay 	DELAY START SET TIME
2. Set delay time 	H 1 00 CHOOSE COOKING MODE
3. Set power level and time	
4. Press start pad 	1H 00













6. GRILL OPERATION

OPERATION	DISPLAY
1. Select grill power press once for grill 1 	GRILL 1 SET TIME 
2. Set cooking time 	1 00 MIN SEC  GRILL 1 PRESS START
3. Press start 	 1 00 MIN SEC 





7. COMBINATION COOKING

OPERATION	DISPLAY
1. Press combination 	COMBINATION SELECT GRILL LEVEL 
2. Press stand 	GRILL 1   SELECT MICROPOWER
3. Select micropower low 	LOW   SET TIME
4. Set cooking time 	1 00 MIN SEC   PRESS START
5. Press start 	 1 00 MIN SEC 

8. AUTOWEIGHT COOK PROGRAM EXCEPT (NN-V687)

OPERATION	DISPLAY
1. Select auto weight program 	CHILLED MEAL   SET WEIGHT
2. Press to select grams or pounds and ounces 	LB OZ   CHILLED PIZZA SET WEIGHT
3. Enter the weight 	1LB OZ   PRESS START
4. Press start 	 6 25 MIN SEC 

9. AUTO SENSOR COOK (NN-V687WB)

OPERATION	DISPLAY
1. Select auto sensor program 	STEAMED PUDDING PRESS START 
2. Press start 	STEAMED PUDDING 

10. TO SET CHILD SAFETY LOCK

OPERATION	DISPLAY
1. Press start 3 times to display lock 	* LOCK

11. TO RESET CHILD LOCK

OPERATION	DISPLAY
1. Press stop/cancel 3 times Time of day or colon appears in display 	11:25

12. DEMONSTRATION MODE

OPERATION	DISPLAY
1. Press clock pad 3 times 	DEMONSTRATION MODE PRESS ANY KEY

13. CANCEL DEMONSTRATION MODE

OPERATION	DISPLAY
1. Press clock pad 3 times 	11:25

3. SCHEMATIC DIAGRAM

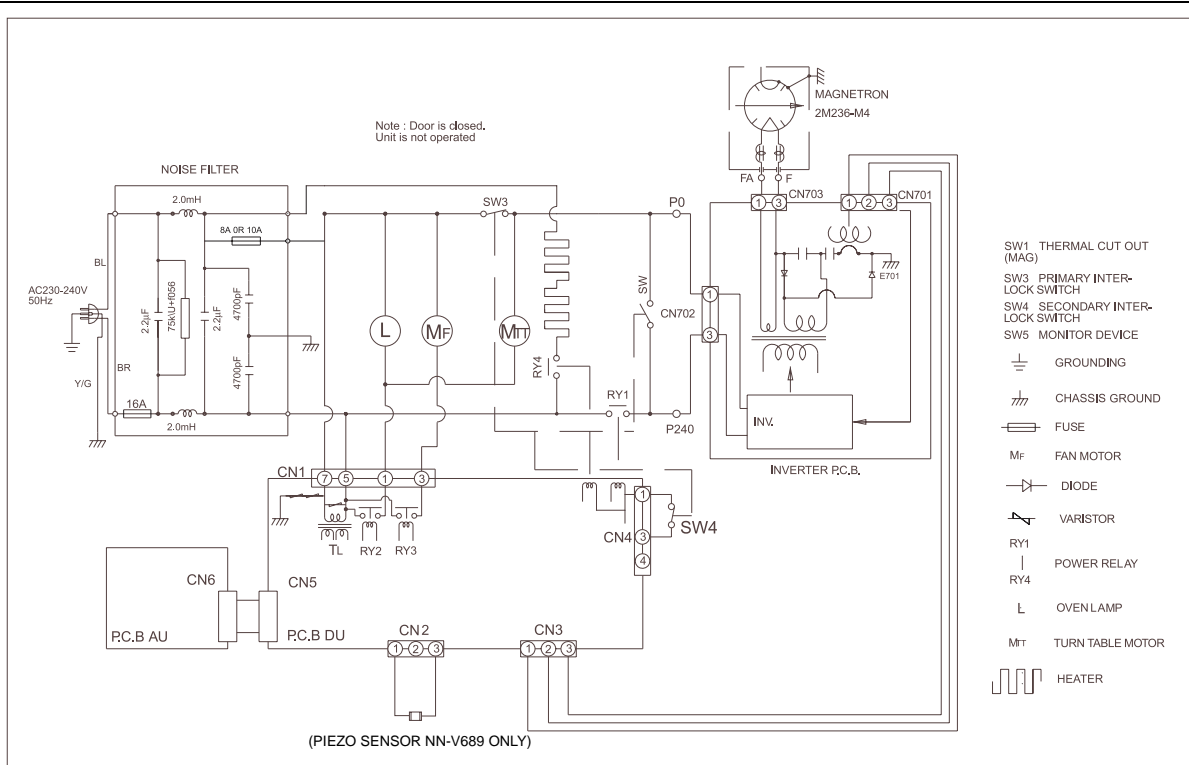

WIRING DIAGRAM

NOTE: *When replacing, check the lead colour as shown.
*Colours shown by () indicate colours of leadwire connector housing.

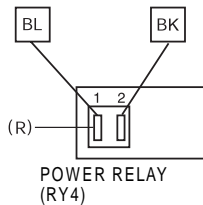
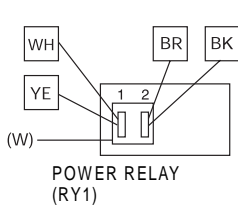
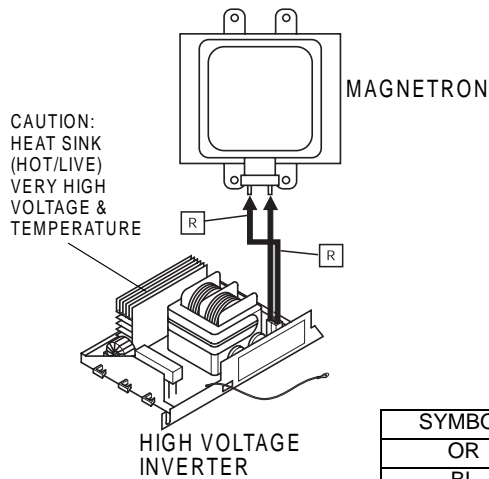
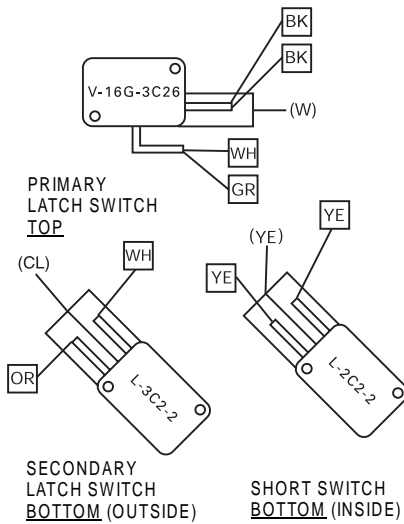

SYMBOL	COLOUR
OR	ORANGE
BL	BLUE
BR	BROWN
W	WHITE
Y	YELLOW
R	RED
GR	GREY
BK	BLACK
CL	CLEAR

4. DESCRIPTION OF OPERATING SEQUENCE

4.1 Variable power cooking control

HIGH VOLTAGE INVERTER POWER SUPPLY (U) controls output power by a signal from Digital Programmer Circuit (DPC). Power relay 1 stays on to supply power to the inverter circuit. The outpower is controlled by the drive signal level from the inverter circuit.

NOTE 1: The ON/OFF time ratio does not correspond with the percentage of microwave power since approximately 2 seconds are required for heating of magnetron filament.

NOTE 2: If microwave cooking is over 8 minutes with HIGH power, fan motor rotates for 1 minute after cooking to cool oven and electric components.

4.2 Grill cooking

The digital programmer circuit operates power relay 4 in the sequence as shown in the table

4.3 Combination cooking

Combination cooking is accomplished by microwave and grill cooking. The digital programmer circuit controls ON-OFF time of power relay 4 and the inverter control signal level, as shown in the table.

NOTE: After grill and combination cooking, fan motor rotates for 1 minute to cool oven and electric components.

4.4 Autoweight defrost, autoweight cook

When those auto control feature is selected and Start pad is pressed:

1. The digital programmer circuit determines the power level and cooking time to complete cooking and indicates the operating state in the display. The table shows the corresponding cooking times for respective weight by categories.
2. When cooking time in the display window has elapsed, the oven turns off automatically by the controlled signal from the digital programmer circuit.

NOTE: After one touch menu and auto reheat cooking, fan motor rotates for 1 minute to cool oven and electric components.

VARIABLE POWER COOKING

POWER SETTING	OUTPUT POWER APPROX.	RY-1	INVERTER CONTROL SIGNAL
HIGH	900W	stay ON	stay ON
DEFROST	270W	stay ON	ON/OFF
MEDIUM	600W	stay ON	stay ON
LOW	440W	stay ON	stay ON
SIMMER	250W	stay ON	ON/OFF
WARM	100W	stay ON	ON/OFF

GRILL COOKING

GRILL NO.	HEATER (RY-4)	
	ON (SEC)	OFF (SEC)
1	33	0
2	24	9
3	18	15

COMBINATION COOKING

COMBINATION NO.	HEATER (RY-4)		MICROPOWER LEVEL			
	ON (SEC)	OFF (SEC)	LOW	SIMMER	WARM	MED
1	33	0	0	0	0	0
2	24	9	0	0	0	0
3	18	15	0	0	0	0

AUTOWEIGHT DEFROST

CATEGORY	WEIGHT	COOKING TIME
BREAD	100g	50 seconds
MEAT ITEMS	150g	2 mins 21 Secs
MEAT JOINTS	400g	7 mins

AUTOWEIGHT COOK

CATEGORY	WEIGHT	COOKING TIME
CHILLED MEAL	200g	2 mins 50 secs
FROZEN MEAL	200g	6 mins 40 secs
FRESH VEG	100g	2 mins 20 secs
FRESH FISH	100g	1 min 10 secs
JACKET POTATOES	200g	9 mins 20 secs
FROZEN POTATOES	100g	4 mins 40 secs

4.5 Auto Sensor cook NN-V689WB

Auto sensor cooking is a revolutionary way to cook by microwave without setting a power level or selecting a time. All that is necessary is to select an Auto Sensor Program before starting to cook.

Understanding Auto Sensor Cooking

As a food cooks, a certain amount of steam is produced. If the food is covered, this steam builds up and eventually escapes from the container. In Auto Sensor Cooking, a carefully designed instrument, called the steam sensor element, senses this escape of steam. Then, based upon the Auto Sensor Programme selected, the unit will automatically determine the correct power level and the proper length of time it will take to cook the food.

NOTE: Auto Sensor Cooking is successful with the foods and recipes found in the Auto Sensor Cooking Guide. Because of the vast differences in food composition, items not mentioned in the Cooking Guide should be prepared in the microwave oven using power select and time features. Please consult Variable Power Microwave Cookbook for procedures.

Explanation of the Auto Sensor Cooking process

1. During the first 10 second period there is no microwave activity, and when calculating the T2 time by using the formula below make sure this 10 seconds is subtracted from the T1 time. In other words the T1 time starts at the end of the 10 second period.
2. **T1 Time...**The total amount of time it takes the microwave oven to switch to T2 time after the 10 second period.
3. **T2 Time...**When the steam escapes from the cooking container placed in the oven, the steam sensor detects it and the microprocessor calculates the balance of the cooking time. This T2 time is then shown on the display and the begins counting down.

Balance of cooking time (T2 time)

The balance of cooking time which is called T2 time, can be calculated by the following formula.

$$T2 \text{ time (in sec.)} = T1 \text{ time} \times K \text{ factor}$$

NOTE: Remember, the T1 time starts after the 10 second period. The coefficient K is programmed into the microprocessor memory and they are listed in the following table along with P1 and P2 powers.

NOTE: When "More" or "Less" pad is selected, the K factor varies resulting in T2 time to be increased or decreased.

Example of calculating T2 time

Example 1: If the T1 time is measured to be 2 minutes and 40 seconds after the 10 second period, and the Auto program selected is Fish:

$$\begin{aligned} T2 &= T1 \times K \\ &= 2 \text{ min. and } 40 \text{ sec.} \times 0.1 \\ &= 160 \text{ sec.} \times 0.1 \\ &= 16 \text{ sec.} \end{aligned}$$

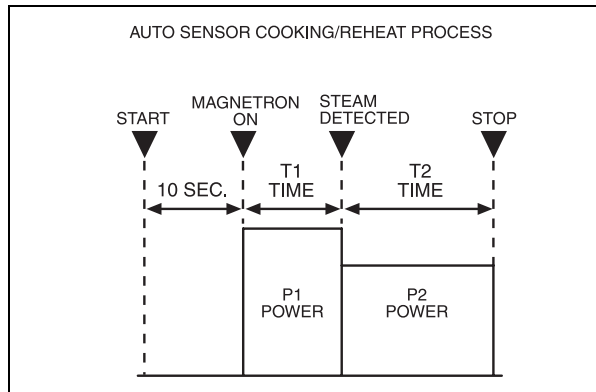

AUTO SENSOR COOK

CATEGORY	P1 POWER	P2 POWER	K FACTOR
FRESH VEG	HIGH	HIGH	0.3
FROZEN VEG	HIGH	HIGH	0.1
FRESH FISH	HIGH	HIGH	0.1
FROZEN FISH	HIGH	HIGH	0.1

AUTO SENSOR COOK COMBINATION

CATEGORY	P1 POWER		P2 POWER		P3 POWER	
	MICRO	GRILL	MICRO	K FACTOR	GRILL	COOK TIME
JACKET POTATOES	HIGH	I	MED	1	1	120s

5. CAUTIONS TO BE OBSERVED WHEN TROUBLESHOOTING

Unlike many other appliances, the microwave oven is high-voltage, high-current equipment. Though it is free from danger in ordinary use, extreme care should be taken during repair.

CAUTION

Servicemen should remove their watches whenever working close to or replacing the magnetron.

5.1 Check the grounding

Do not operate on a 2-wire extension cord. The microwave oven is designed to be used when grounded. It is imperative, therefore, to make sure it is grounded properly before beginning repair work.

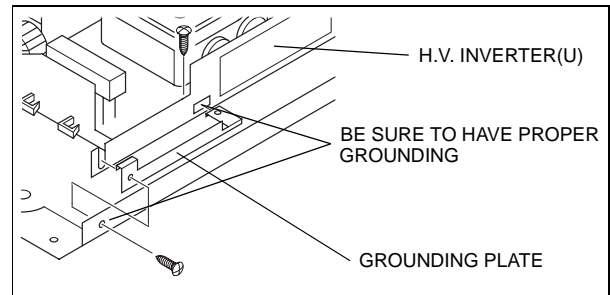

5.2 Inverter Warnings **NEW H.V.**

DANGER OF HIGH VOLTAGE AND HIGH TEMPERATURE (HOT/LINE) OF THE INVERTER POWER SUPPLY (U)

This High Voltage Inverter Power Supply circuit handles very high voltage and very high current for the magnetron tube. Though it is free from danger in ordinary use, extreme care should be taken during repair. As you can see, it looks like a TV flyback transformer, however the current is extremely large and so danger exists by its high current and high voltages.

The aluminium heat sink is also energized with high voltage (HOT), so do not touch when AC input terminal is connected to the power devices (Collector) is directly connected to the Aluminium heat sink.

The Aluminium heat sink may be HOT by heat energy; therefore, extreme care should be taken during servicing and replacing.

WARNING OF DISCHARGING HIGH VOLTAGE CAPACITORS

Warning about the electric charge in the high voltage capacitors. For about 30 seconds after the oven is turned off, an electric charge remains in the high voltage capacitors in the inverter power supply circuit board.

When replacing or checking parts, remove the power plug from the outlet and short the Inverter output terminal of the magnetron filament terminals to the chassis ground with an insulated handle screwdriver to discharge. Please make sure to touch chassis ground side first then short to the output terminals.

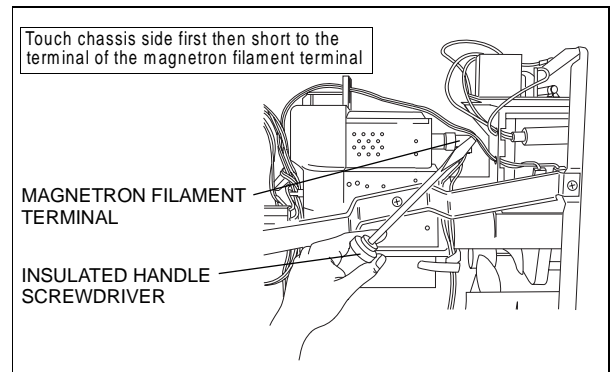
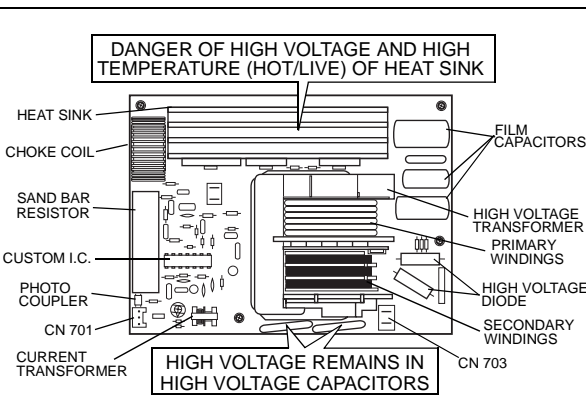

WARNING

There is high-voltage present, with high-current capabilities in the circuits of the primary, and secondary windings, choke coil and heat sink of the Inverter. It is extremely dangerous to work on or near these circuits with oven energized. DO NOT measure the voltage in the high voltage circuit including filament voltage of magnetron.

WARNING OF INVERTER POWER SUPPLY(U) GROUNDING

Check the High Voltage Inverter Power Supply circuit grounding. This High Voltage Inverter Power Supply circuit board must have a proper chassis ground by the grounding bracket to the chassis ground; otherwise, this H.V. Inverter circuit board will expose very high voltage and cause extreme DANGER! Be sure to have proper grounding by the grounding plate and screws.

WARNING

Never touch any circuit wiring with your hand nor with an insulated tool during operation.

5.3 When parts must be replaced, remove the power plug from the outlet.

5.4 When the 10A fuse is blown due to the operation of short switch:

WARNING

When the 10A 250V. fuse is blown due to the operation of short switch, you must replace Primary latch switch and short switch. Also replace power relay 1 (RY1) when the continuity check reads shorted contacts (1-2).

1. This is mandatory. Refer to “Adjustments and Measurement” for these switches.
2. When replacing the fuse, confirm that it has the appropriate rating for these models.
3. When replacing faulty switches, be sure mounting tabs are not bent, broken or otherwise deficient in their ability to hold the switches.

5.5 Avoid inserting nails, wire, etc. through any holes in the unit during operation.

Never insert a wire, nail or any other metal object through the lamp holes on the cavity or any other holes or gaps, because such objects may work as an antenna and cause microwave leakage.

5.6 Confirm after repair

1. After repair or replacement of parts, make sure that the screws of the oven, etc. are neither loose nor missing. Microwaves might leak if screws are not properly tightened.
2. Make sure that all electrical connections are tight before inserting the plug into the wall outlet.
3. Check for microwave energy leakage. (Refer to procedure for measuring microwave energy leakage).

CAUTION

MICROWAVE RADIATION

DO NOT BECOME EXPOSED TO RADIATION FROM THE MICROWAVE GENERATOR OR OTHER PARTS CONDUCTING MICROWAVE ENERGY.

IMPORTANT NOTICE **NEW H.V.**

1. The following components have potentials above 250V while the appliance is operated.

- Magnetron
- High voltage transformer (Located on Inverter(U))
- High voltage diodes (Located on Inverter(U))
- High voltage capacitors (Located on Inverter(U))

Pay special attention on these areas.

When the appliance is operated with the door hinges or magnetron is fixed incorrectly, the microwave leakage can reach more than 5mW/cm³. After repair or exchange, it is very important to check if the magnetron and the door hinges are correctly fixed.

6. DISASSEMBLY AND PARTS REPLACEMENT PROCEDURE

6.1 Magnetron

1. Discharge the high voltage capacitors.
2. Remove 1 screw holding the air guide A.
3. Remove 2 screws holding the tie bar.
4. Remove the oven lamp and lead wire harness cables from the Air guide A.
5. Remove the Air Guide A
6. Disconnect the 2 high voltage lead wires from the magnetron.
7. Remove 4 screws holding the magnetron.

NOTE: After replacement of the magnetron, tighten mounting screws properly making sure there is no gap between the waveguide and the magnetron to prevent microwave leakage.

CAUTION

When replacing the magnetron, be sure the antenna gasket is in place.

NOTE

Magnetron used for this model is unique type for inverter power supply system. Make sure to use the one as listed in the part list.

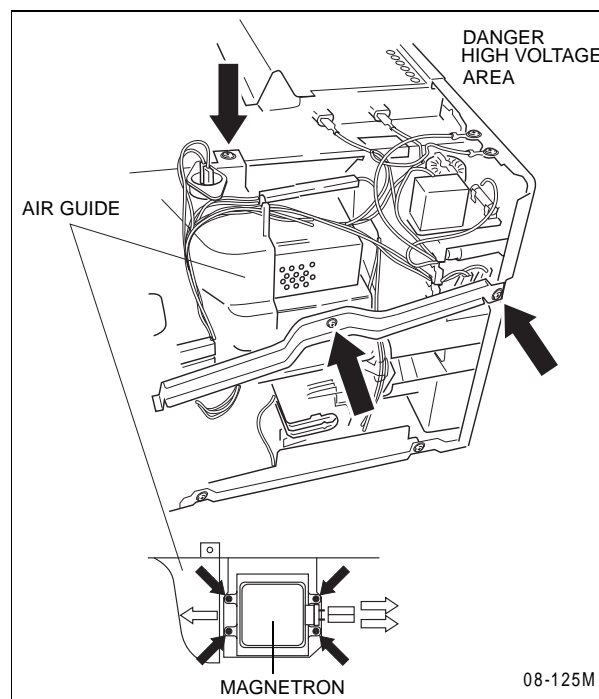

6.2 Inverter Power Supply(U) **NEW H.V.**

1. Discharge the high voltage capacitors.
2. Unplug 3 lead wire connectors from the Inverter Power Supply board.
3. Remove 1 screw to release the inverter grounding bracket.
4. Remove 1 screw and remove the inverter PCB plus support base from the oven.
5. Remove 1 screw to disconnect earth wire to magnetron.
6. Remove 4 screws holding inverter power supply board to the Inverter bracket.
7. Replace with replacement PCB and follow the steps in reverse.

CAUTIONS WHILE REPLACING INVERTER POWER SUPPLY(U)

1. Make sure to leave grounding plate in its place.
2. Make sure to securely tighten grounding screw through the side of chassis (base).
3. Securely connect 3 lead wire connectors.
4. Make sure the heat sink has enough space (gap) from the oven. Take special care not to touch any lead wire to the aluminium heat sink because it is hot.

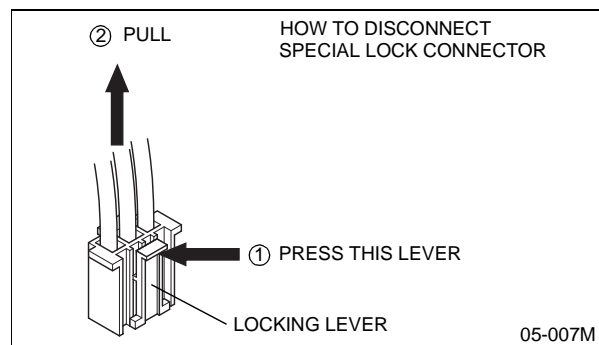
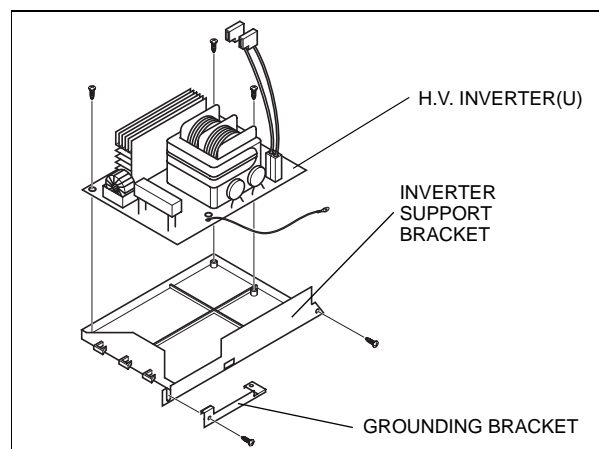

6.3 Digital Programmer Circuit (DPC) and membrane key board.

NOTE: Be sure to ground any static electric charge built up on your body before handling the DPC.

1. Disconnect all connectors from D.P.C.
2. Remove 2 screws holding escutcheon base and slide the escutcheon base upward slightly.
3. Remove 1 screw holding earth wire to the chassis.
4. Release flat cable.
5. Remove 6 screws holding DPC DU.
6. Remove door lever.
7. Remove 6 screws holding DPC AU.

To replace membrane key board

8. Remove escutcheon bracket from escutcheon base by freeing 4 catch hooks on the escutcheon base.
9. Remove display window.
10. Remove membrane assembly by pushing away from base.

NOTE: 1. The membrane key board is attached to the escutcheon base with double faced adhesive tape. Therefore, applying hot air such as using a hair dryer is recommended for smoother removal.

2. When installing new membrane key board, make sure that the surface of escutcheon base is cleaned sufficiently so that any problems (shorted contacts or uneven surface) can be avoided.

3. When replacing the silver escutcheon sheet (NN-V629MB) ensure the escutcheon sheet is earthed to the backplate via the earth strip.

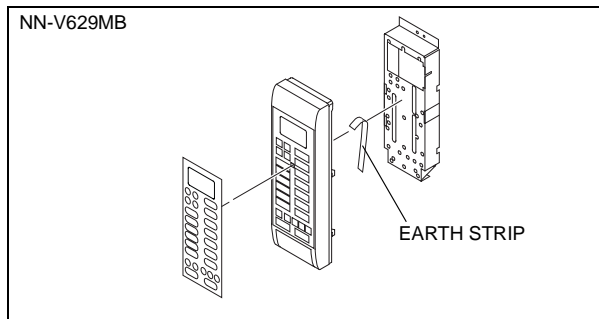
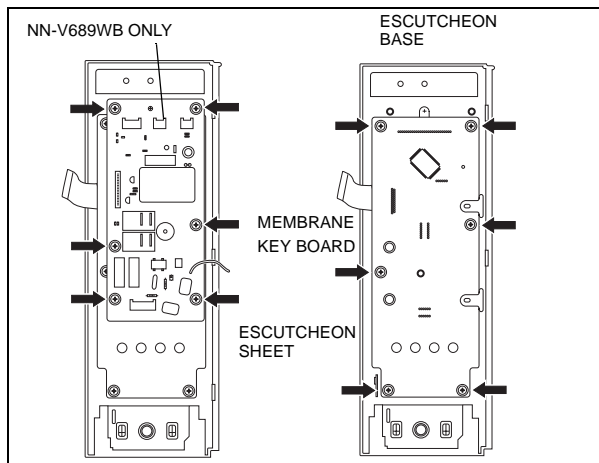

6.4 Low voltage transformer and/or power relays (RY1)

NOTE: Be sure to ground any static electric charge built up on your body before handling the DPC.

1. Using solder wick or a desoldering tool and 30W soldering iron, carefully remove all solder from the terminal pins of the low voltage transformer and/or power relays.

NOTE: Do not use a soldering iron or desoldering tool of more than 30 watts on DPC contacts.

2. With all the terminal pins cleaned and separated from DPC contacts, remove the defective transformer/power relays and install new transformer/power relays making sure all terminal pins are inserted completely. Resolder all terminal contacts carefully.

6.5 Fan Motor

1. Remove 2 screws and remove tie bar.
2. Disconnect 2 lead wires from fan motor terminals.
3. Disconnect all lead wires from noise filter.
4. Remove the noise filter.
5. Remove 4 screws holding fan motor and upper and lower orifice. Detach the orifice assembly with fan motor from oven assembly.
6. Remove fan blade from the fan motor shaft by pulling it straight out.

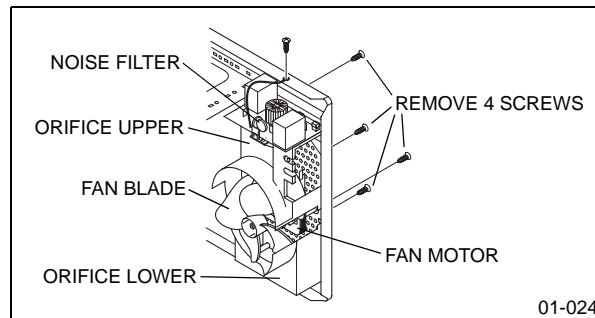

01-024

6.6 Door disassembly

1. Remove door C from door E by carefully pulling outward starting from upper right hand corner using a flat blade screwdriver.
2. Remove 4 screws holding door E to door A assembly to separate door E from door A.
3. Remove door key and door key spring.

After replacement of the defective component parts of the door, reassemble it and follow the instructions below for proper installation and adjustment so as to prevent an excessive microwave leakage.

1. When mounting the door to the oven, be sure to adjust the door parallel to the bottom line of the oven face plate by moving the upper hinge and lower hinge in the direction necessary for proper alignment.
2. Adjust so that the door has no play between the inner door surface and oven front surface. If the door assembly is not mounted properly, microwave power may leak from the clearance between the door and oven.
3. Perform the microwave leakage test.

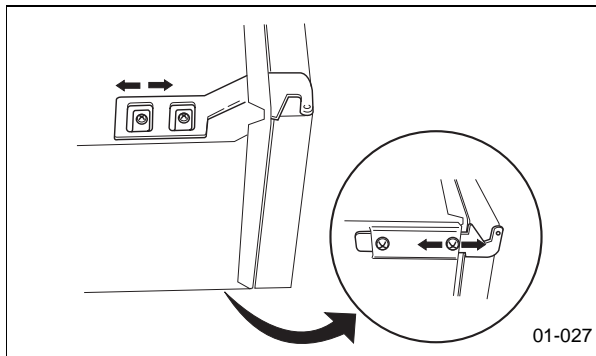
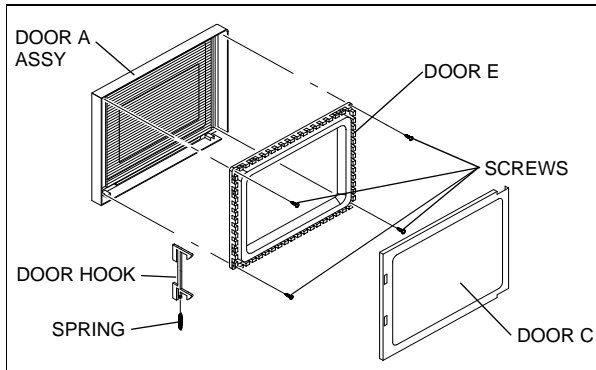

6.7 Turntable motor

1. Remove the motor cover by breaking off at the 8 spots indicated by arrows. (See Figure)

NOTE: After breaking off the motor cover, make sure that cut-off portions are properly trimmed off or bend to inside so that no sharp edge will expose to outside.

2. Disconnect 2 lead wires connected to the turntable motor.
3. Remove the turntable motor by removing 2 screws.

NOTE: To reinstall the motor cover, use 4x6 screw.

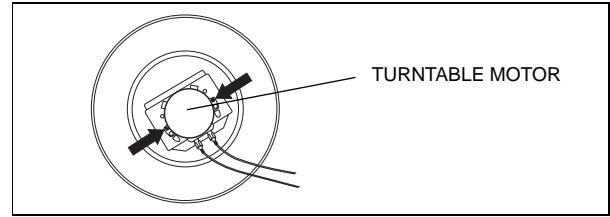

6.8 Quartz heater

1. Disconnect lead wires from heater terminals.
2. Remove 1 screw holding heater supports.
3. Remove the heater.

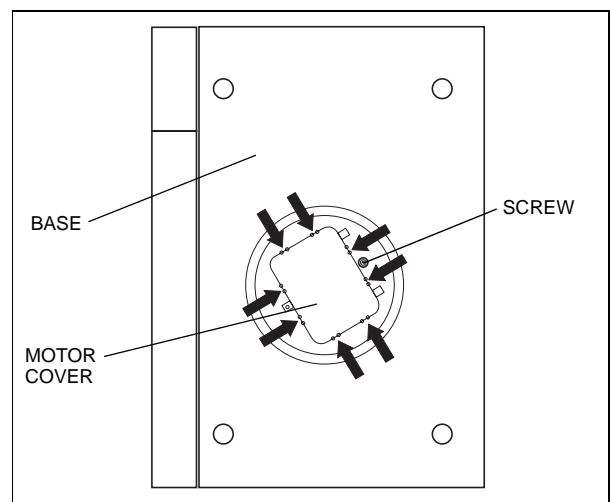
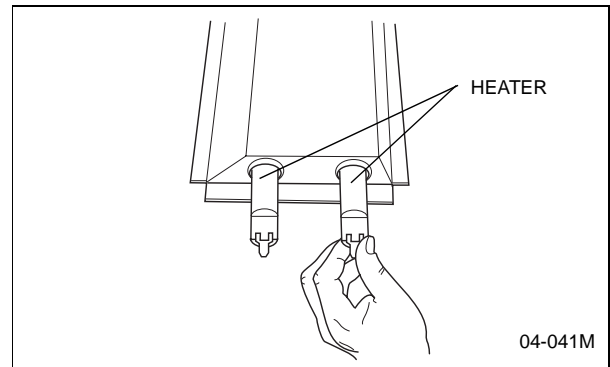
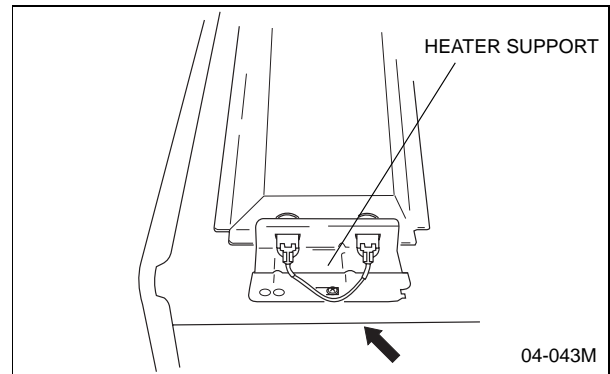

6.9 Steam Sensor NN-V689WB

1. Remove 1 screw holding steam sensor unit.
2. Disconnect CN2 connector from digital programmer circuit board.
3. Remove exhaust guide from steam sensor unit.
4. Remove catch hooks on sensor mounting plate and air guide.
5. Remove steam sensor from sensor mounting plate.

NOTE: When installing the steam sensor, make sure that the direction of the steam sensor is as shown in figure.

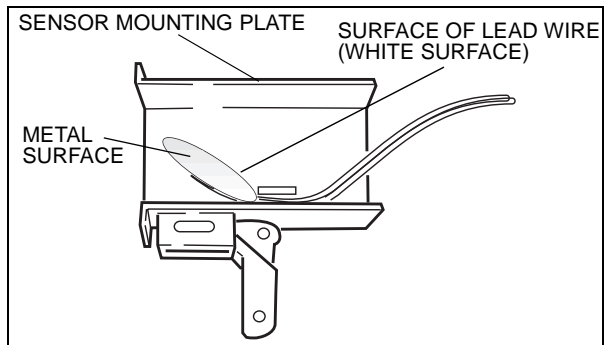
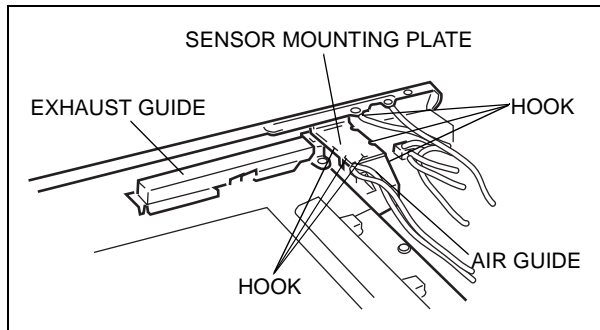

7. COMPONENT TEST PROCEDURE

CAUTION **NEW H.V.**

1. High voltage is present at the high voltage terminal of the High Voltage Inverter(U) including aluminium heat sink during any cook cycle.
2. It is neither necessary nor advisable to attempt measurement of the high voltage.
3. Before touching any oven components, or wiring, always unplug the oven from its power source and discharge the high voltage capacitors.

7.1 Primary Latch Switch, Secondary (Secondary Latch Switch and Power Relay B) Interlocks.

1. Unplug the lead connectors to Power Relay B and verify continuity of the power relay B 1-2 terminals.
2. Unplug lead connectors to Primary Latch Switch and Secondary Latch Switch.
3. Test the continuity of switches at door opened and closed positions with ohm meter (low scale).

Normal continuity readings should be as follows.

	Door Opened	Door Closed
Primary Latch Switch	$\infty \Omega$ (open)	0 Ω (close)
Secondary Latch Switch	$\infty \Omega$ (open)	0 Ω (close)
Power Relay B	$\infty \Omega$ (open)	$\infty \Omega$ (close)

7.2 Short Switch & Monitor Circuit **NEW H.V.**

1. Unplug lead wires from H.V. Inverter primary terminals.
2. Connect test probes of ohm meter to the disconnected leads which were connected to H.V. Inverter.
2. Test the continuity of short switch with door opened and closed positions using lowest scale of the ohm meter.

Normal continuity readings should be as follows.

Door Opened	Door Closed
0 Ω	$\infty \Omega$

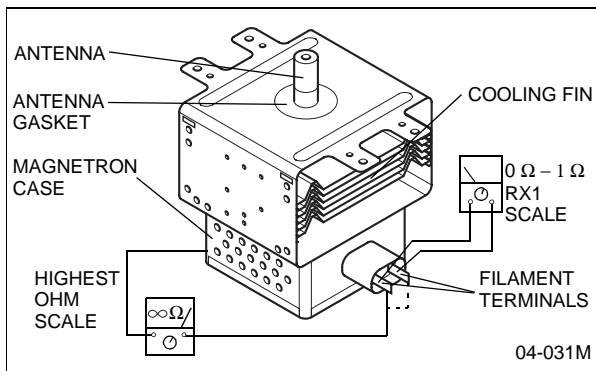

7.3 Magnetron

Continuity checks can only indicate an open filament or a shorted magnetron. To diagnose for an open filament or shorted magnetron.

1. Isolate magnetron from the circuit by disconnecting the leads
2. A continuity check across magnetron filament terminals should indicate one ohm or less.
3. A continuity check between each filament terminal and magnetron case should read open.

7.4 Push button key board

Check continuity between switch terminals, by tapping an appropriate pad on the key board. The contacts assignment of the respective pads on the key board is as shown in digital programmer circuit (schematic).

7.5 Inverter Power Supply (U)

DO NOT try to REPAIR this H.V. Inverter power supply(U). Replace as whole H.V. Inverter(U) Unit.

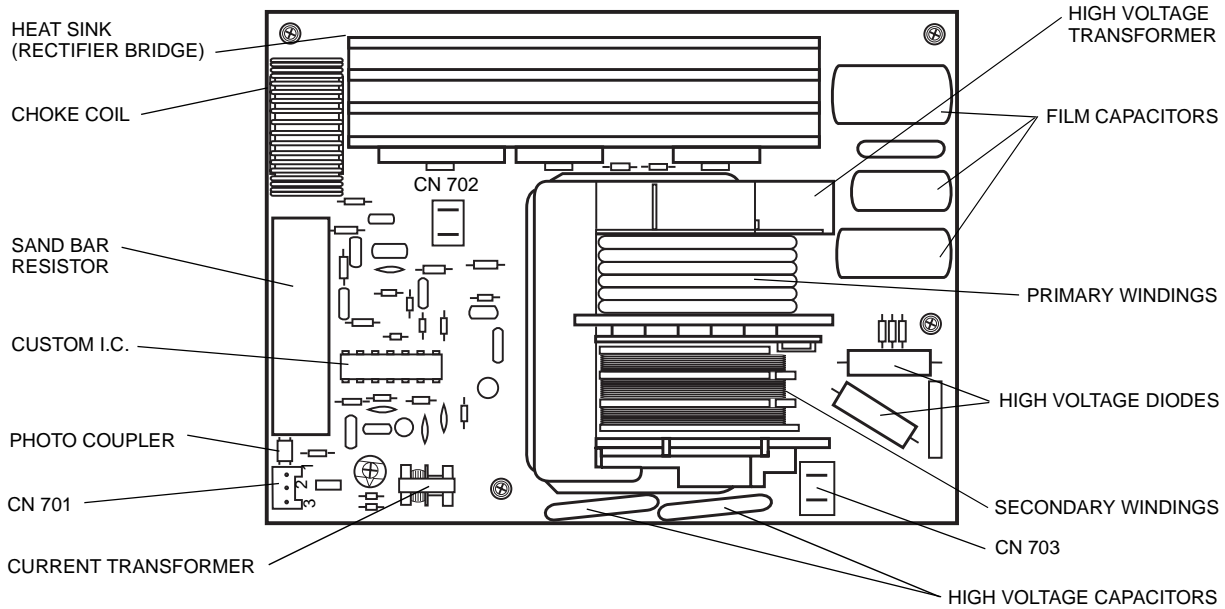

INVERTER POWER SUPPLY DIAGRAM

7.6 Inverter Power supply(U) **NEW H.V.**

WARNING

Do not attempt to make any measurements in the high voltage circuitry of the inverter or magnetron.

See Troubleshooting of inverter circuit and magnetron on Pages 19 and 20 to determine if the inverter power supply is functioning.

T1 TIME	T2 TIME (Remaining cooking time)
1 Min. 30 Sec. ~ 4 Min.	8 Sec. ~ 23 Sec.

7.7 Steam Sensor and digital programmer circuit

CAUTION

Do not touch any parts of the circuitry on the digital programmer circuit since static electric discharge may damage this control panel.

Always ground yourself while working on this panel to discharge any static built up on your body.

In order to determine if the steam sensor programme of the digital programmer circuit is in working order or not, do the following test.

1. Place a water load (150cc) in the oven.
2. Set Auto Sensor Program 5 Fresh Fish.
3. Tap Start pad.
4. Steam Sensor detects steam about 1 minute 30 seconds to 4 minutes after the Start pad is tapped.
5. T1 time cooking automatically switches to remaining time cooking. (T2)
6. The remaining cooking time (T2) appears in the display window. If the following cooking times appear Steam Sensor function is normal.

8. MEASUREMENTS AND ADJUSTMENTS

WARNING

- For continued protection against radiation hazard, replace only with identical replacement parts.
- When the 10 Amp. fuse is blown due to the operation of short switch, you must replace Primary latch switch and short switch. Then follow the installation procedures below.
- Interlock switch replacement - In replacing faulty switches, be sure mounting tabs are not bent, broken or otherwise deficient in their ability to hold the switches.
- Refer to schematic diagram to ensure proper connection.

8.1 Installation of Primary latch switch, Secondary latch switch and Short switch.

1. When mounting Primary latch switch, Secondary latch switch and short switch to door hook assembly, mount the Primary latch switch, the Secondary latch switch and the short switch to the door hook assembly as shown in the illustration.

NOTE: No specific adjustment during installation of Primary latch switch, Secondary latch switch and short switch to the door hook is necessary.

2. When mounting the door hook assembly to the oven assembly, adjust the door hook assembly by moving it in the direction of arrow in the illustration so that the oven door will not have any play in it. Check for play in the door by pulling the door assembly. Make sure that the latch keys move smoothly after adjustment is completed. Completely tighten the screws holding the door hook assembly to the oven assembly.
3. Reconnect the short switch, primary & secondary latch switches and check the continuity of the monitor circuit and all latch switches again by following the components test procedures.

8.2 Measurement of microwave output

The output power of the magnetron can be determined by performing IEC standard test procedures. However, due to the complexity of IEC test procedures, it is recommended to test the magnetron using the simple method outlined below.

Necessary Equipment:

*1 litre beaker

*Glass thermometer

*Wrist watch or stopwatch.

NOTE: Check the line voltage under load. Low voltage will lower the magnetron output. Take the temperature readings and heating time as accurate as possible.

1. Fill the beaker with exactly one litre of tap water. Stir the water using the thermometer and record the beaker's temperature (recorded as T1).
2. Place the beaker on the center of glass cook plate.
3. Stir the water again and read the temperature of the beaker (recorded as T2).
4. The normal temperature rise at High power position for each model is as shown in table.

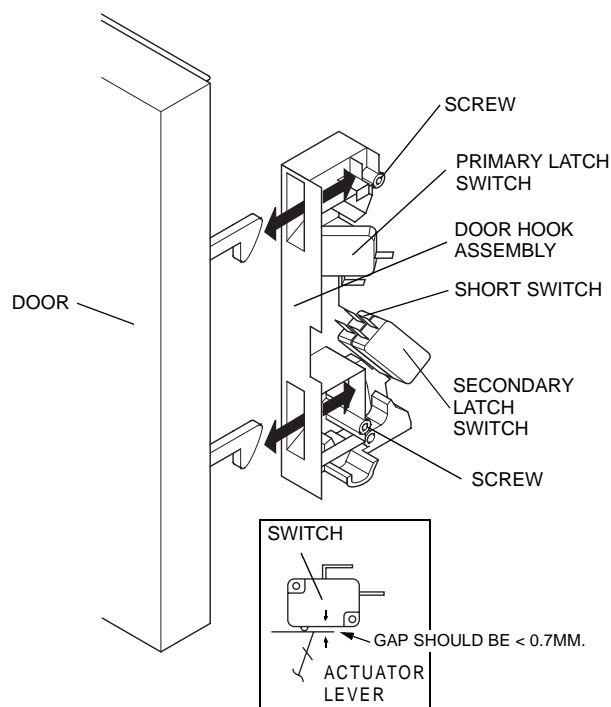

Please confirm that the gap between the switch housing and switch actuator levers is no more than 0.7 mm when the door is closed.

01-033

TABLE (1 ℓ - 1min. test)

RATED OUTPUT	TEMPERATURE RISE
900W (IEC705-88)	(10°C)

9. TROUBLESHOOTING GUIDE NEW H.V.

CAUTION

1. **DO NOT try to REPAIR this H.V. Inverter power supply(U). Replace as whole H.V. Inverter(U) Unit.** When returning H.V. Inverter(U) make sure to pack as originally packed.
2. **DO NOT RE-ADJUST PRESET VOLUME on the H.V. Inverter(U).** It is very dangerous to repair or adjust without sufficient test equipment because this circuit handles very large current with very high voltage.
3. Ensure proper grounding before checking for trouble.
4. Be careful of the high voltage circuitry, taking necessary precautions when troubleshooting.
5. Discharge the high voltage that remains in the Inverter(U).
6. When checking the continuity of the switches or the H.V. Inverter, disconnect one lead wire from these parts and then check continuity with the AC plug removed. To do otherwise may result in a false reading or damage to your meter. When disconnecting a plastic connector from a terminal, you must hold the plastic connector instead of the lead wire and then disconnect it, otherwise lead wire may be open or the connector cannot be removed.
7. Do not touch any parts of the circuitry on the digital programmer circuit, since static electric discharge may damage this control panel.
Ensure you are touching the ground while working on this panel to discharge any static charge in your body.
8. 240VAC is present on the digital programmer circuit (Terminals of power relay's and primary circuit of low voltage transformer). When troubleshooting, be cautious of possible electrical shock hazard.

Before troubleshooting, operate the microwave oven following the correct operating procedures in the instruction manual in order to find the exact cause of any trouble, since operator error may be mistaken for the oven's malfunction.

	SYMPTOMS	CAUSE	CORRECTIONS
1.	Oven is dead. Fuse is OK. No display and no operation at all.	1. Open or loose lead wire harness. 2. Open low voltage transformer 3. Defective DPC AU or DPC DU	
2.	No display and no operation at all. Fuse is blown.	1. Shorted lead wire harness 2. Defective primary latch switch (NOTE 1) 3. Defective short switch (NOTE 1) 4. Defective Inverter power supply (U) NEW H.V. Refer to component test procedure (Page 17)	Check adjustment of primary, secondary latch switch and short switch including door.
		NOTE 1: All of these switches must be replaced at the same time. (Refer to adjustment instructions.) Check continuity of power relay B's contacts (between 1 and 2) and if it has continuity, replace power relay B also.	
3.	Oven does not accept key input (Program).	1. Key input is not in sequence. 2. Shorted push button on DPC AU. 3. Defective DPC AU.	Refer to operation procedure. Refer to DPC troubleshooting.
4.	Oven lamp and turntable motor turn on when oven is plugged in with door closed	1. Misadjustment or loose wiring of secondary latch switch. 2. Defective secondary latch switch	Adjust door and latch switches.
5.	Timer starts countdown but no microwave oscillation. (No heat while oven lamp and fan motor turn on)	1. Off-alignment of latch switches 2. Open or loose connection of high voltage circuit especially magnetron filament circuit NOTE: Large contact resistance will bring lower magnetron filament voltage and cause magnetron to have lower output and/or be intermittent. 3. Defective high voltage component H.V. Inverter NEW H.V. Magnetron 4. Open or loose wiring of power relay B 5. Defective primary latch switch. 6. Defective power relay B or DPC AU or DU.	Adjust door and latch switches. Check high voltage component according to component test procedure (Page 17) and replace if it is defective. Refer to DPC troubleshooting.
6	Microwave output is low. Oven takes longer time to cook food.	1. Decrease in power source voltage 2. Open or loose wiring of magnetron filament circuit. (Intermittent oscillation) 3. Aging change of magnetron.	Consult electrician Refer to output test procedures by water temperature raising test.
7	Turntable on when door is opened.	1. Shorted primary latch switch.	
8	Loud buzzing noise can be heard.	1. Loose fan and fan motor	

	SYMPTOMS	CAUSE	CORRECTIONS
9	Turntable motor does not rotate.	1. Open or loose wiring of turntable motor 2. Defective turntable motor	
10	Oven stops operation during cooking.	1. Open or loose wiring of primary and secondary latch switch	Adjust door and latch switches.
11	Oven returns to plug in mode 9 secs. after pad is pressed in sensor mode.	1. Open steam sensor 2. Defective steam sensor	NN-V689WB

Troubleshooting of Inverter Circuit (U) and Magnetron **NEW H.V.**

Oven shuts down after approximately 15 or 33 seconds.

If the microwave oven shuts down after a short time in micropower mode, conduct the following test.

The microwave oven must be set in test mode to activate the self diagnostic failure code system.

SELF TEST MODE

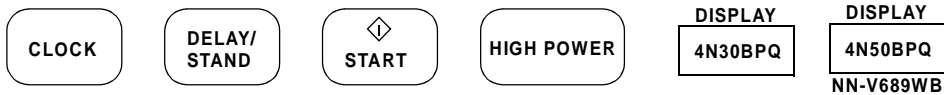

When oven is set in test mode place water load in oven, set micropower to high and time to 1 minute, press start.

H97, H98 appears in display window a short time after start key is pressed and there is no microwave oscillation.

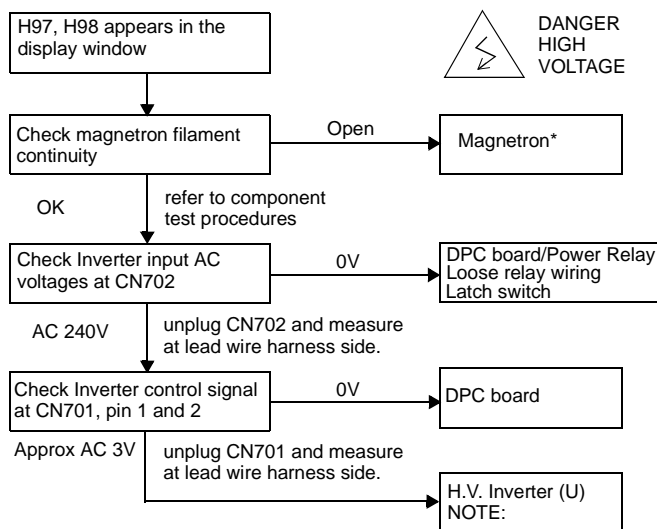

NOTE: DO NOT try to REPAIR this Inverter Power Supply(U) and also DO NOT RE-ADJUST PRESET VOLUME on the board. It is very dangerous to repair or adjust without sufficient test equipment because this circuit handles very high voltage and very large current. Off alignment of inverter board operation is dangerous. Operating a misaligned Inverter circuit is dangerous due to the very high voltage and current that is produced by this board. Defective boards must be replaced with a new one.

*Check magnetron filament for open or short to casing before proceeding to determine a good magnetron.

Alternative way to troubleshooting oven with AC Ampare meter used. NEW H.V.

Oven shuts down after approximately 15 or 33 seconds.

If the microwave oven shuts down after a short time in micropower mode, conduct the following test.

The microwave oven must be set in test mode to activate the self diagnostic failure code system.

SELF TEST MODE

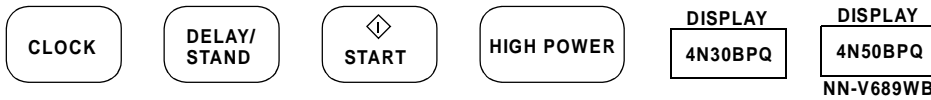

When oven is set in test mode place water load in oven, set micropower to high and time to 1 minute, press start.

H97, H98 appears in display window a short time after start key is pressed and no microwave oscillation with AC Ampare meter used for troubleshooting.

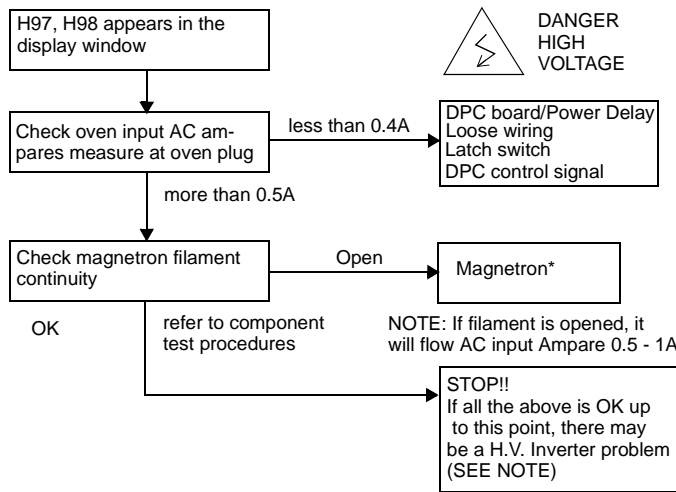

NOTE: DO NOT try to REPAIR this Inverter Power Supply(U) and also DO NOT RE-ADJUST PRESET VOLUME on the board. It is very dangerous to repair or adjust without sufficient test equipment because this circuit handles very high voltage and very large current. Off alignment of inverter board operation is dangerous. Operating a misaligned Inverter circuit is dangerous due to the very high voltage and current that is produced by this board. Defective boards must be replaced with a new one.

NOTE: If filament is opened, it will flow AC input Ampare 0.5 - 1A

*Check magnetron filament for open or short to casing before proceeding to determine a good magnetron.

Trouble Related to Digital Programmer Circuit

SYMPTOM	STEP	CHECK	RESULT	CAUSE/CORRECTIONS
No display when oven is first plugged in.	1	Fuse pattern of DPC	Normal	STEP 2
			Open (NOTE)	Shorted Circuit of ZNR, L.V.T., Oven Lamp etc. Replace DPC
Oven is dead.	2	IC10 Pin 9 (12V line)	Abnormal 0V	IC10
			Normal 12V	→ Step 3
	3	IC-1 Pin 16 voltage (Emitter of Q10)	Abnormal	ZD10, Q10, Ribbon Cable
			Normal = 5V	→ Step 4
4	IC-1 pin 10 voltage (15 pin of IC220)	Abnormal	IC-220	
		Normal	→ IC-1, CX1	

NOTE

Procedure of fuse pattern repairing is as follows:

1. When the fuse pattern (PF2) opens.

(1) Remove the jumper wire (PF3).

(2) Insert the removed jumper wire (PF3) to "(PF2)" position and solder it. If both "PF2" and "PF3" fuse patterns are open, please replace DPC.

NOTE: * At the time of these repairs, make visual inspection of the varistor for burning damage and examine the transformer with tester for the presence of layer short-circuit (check primary coil resistance).

If any abnormal condition is detected, replace the defective parts.

SYMPTOM	STEP	CHECK	RESULT	CAUSE/CORRECTIONS
No key input	1	Push button switch	Abnormal	Push button switch
			Normal	IC-1
No beep sound	1	IC-1 pin 8, voltage	Abnormal	IC-1
			Normal	IC220, BZ310
Power relay A(RY-2) does not turn on even though the program has been set and the start pad is tapped.	1	IC-1 pin 11 voltage while operation	Abnormal	IC-1
			Normal = 5V	→ Step 2
No microwave oscillation at any power setting.	2	Short circuit between pin 6 and pin 16 of IC-2	Still not turn on	RY-2
			RY-2 turns on	IC-220
No microwave oscillation at any power setting.	1	IC-1 pin 7 and 72 voltages while operation at high power	Abnormal	IC-1
			Normal 7---5V, 72---5V	→ Step 2
Dark or unclear display	2	Q220 transistor	Abnormal	Q220
			Normal	IC220
Dark or unclear display	1	Replace display and check operation	Normal	DISPLAY
			Abnormal	IC-1
Missing or lighting of unnecessary segment	1	Replace IC-1 and check operation	Normal	IC-1
			Abnormal	DISPLAY
Oven shuts down on Micropower after a short time (set in test mode) (set high power 1 Min) H97/H98 appears in window and oven stops operation. Program High power for 1 minute and conduct following test quickly, unless H97/H98 appears and oven stops. NEW H.V.	1	Unplug CN702(2 pin) connector and measure voltage between terminals	0V	1. Latch switch 2. DPC/Power relay
			AC line voltage of 240V	→ Step 2
Oven shuts down on Micropower after a short time (set in test mode) (set high power 1 Min) H97/H98 appears in window and oven stops operation. Program High power for 1 minute and conduct following test quickly, unless H97/H98 appears and oven stops. NEW H.V.	2	Unplug CN701(3 pin) connector and measure pin 1 voltage	0V	1. DPC
			Approx. AV 3V	1. Magnetron 2. Inverter

How to Check the Semiconductors Using an OHM Meter

Diode

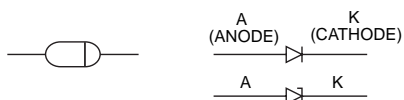

Transistor

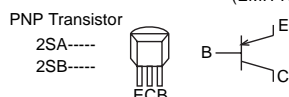
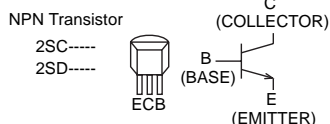

Digital Transistor PNP Transistor

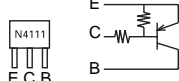

	FORWARD	REVERSE
A-K	SMALL	∞

	FORWARD	REVERSE
B-E	SMALL	∞
B-C	SMALL	∞
C-E	∞	∞

	FORWARD	REVERSE
E-B	SMALL	∞
C-B	SMALL	∞
C-E	∞	∞

	FORWARD	REVERSE
E-B	10kΩ-30kΩ	10kΩ-30kΩ
C-B	50kΩ-90kΩ	∞
C-E	40kΩ-80kΩ	∞

10. EXPLODED VIEW AND PARTS LIST

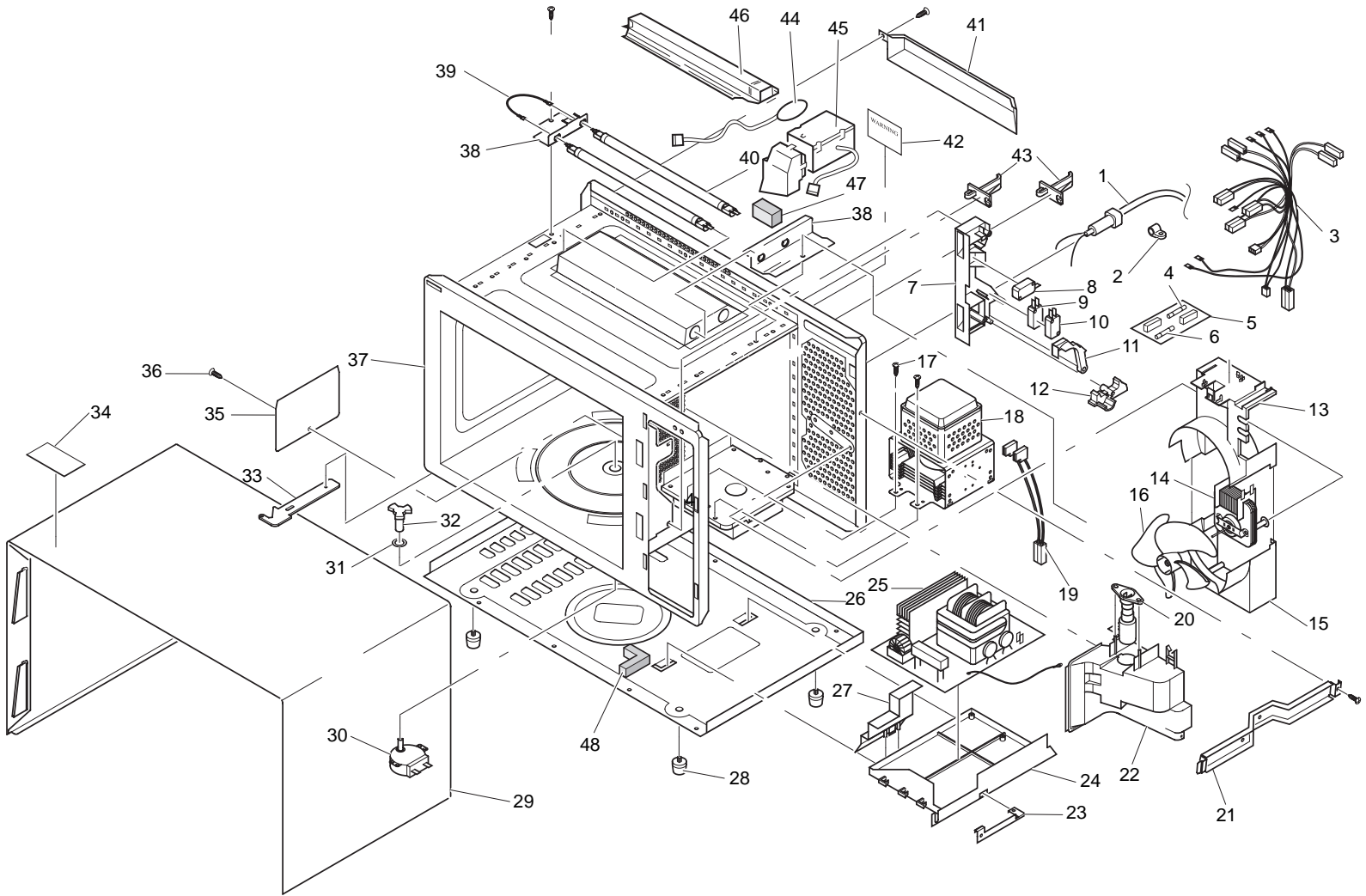

11. PARTS LISTS

NOTES: *When ordering replacement part(s), please use part number(s) shown in this parts list.

Do not use description of the part.

*Important safety notice:

Components identified by ! mark have special characteristics important for safety. When replacing any of these components, use only manufacturer's specified parts.

Ref. No		Part No.	Part Name and Description	Pcs/set	Remarks
1	!	E900C6520BP	POWER SUPPLY CORD	1	
2		AEE9108A20GN	POWER CORD CLIP	1	
3	!	E030A4N30BP	LEAD WIRE HARNESS	1	
4	!	AEE6230P10GN	FUSE (16A)	1	16A
5	!	E607X4N30BP	NOISE FILTER	1	
6	!	E67597550GP	CERAMIC FUSE (10A)	1	10A
7		E30208000BP	DOOR HOOK	1	
8	!	AEE6142-F61	PRIMARY LATCH SWITCH	1	V-15G-3C26
9	!	E61785180AP	SHORT SWITCH	1	L-2C2-2
10	!	E61425180AP	SECONDARY LATCH SWITCH	1	L-3C2-2
11		E31384830AP	HOOK SPACER C	1	
12		E31374830AP	HOOK SPACER B	1	
13		E41444N30BP	UPPER ORIFICE	1	
14	!	E400A4760JP	FAN MOTOR	1	
15		E42094N30BP	LOWER ORIFICE	1	
16		E4008-1640	FAN BLADE	1	
17		XTWANE4+12B	SCREW	1	FOR MAGNETRON
18	!	2M236-M42E2	MAGNETRON	1	
19	!	E030E4N30BP	HV LEAD WIRE	1	
20	!	E610T6700BP	OVEN LAMP	1	
21		E20994N30BP	BRACKET A	1	
22		E40254N30BP	AIR GUIDE A	1	
23		E66014L00GS	INVERTER EARTH BRACKET	1	
24		E65854L00GS	INVERTER SUPPORT BRACKET	1	
25	!	E606Y4N10GP	INVERTER	1	
26		E10014N30BP	BASE PLATE	1	
27		E10614L00GS	WATER SHIELD	1	
28		E1008-1180	RUBBER FOOT	1	
29		E110D4N30HGP	OUTER PANEL	1	NN-V689WB NN-V659WB
29		E110D4N30GP	OUTER PANEL	1	NN-V659CB
29		E110D4N30NGP	OUTER PANEL	1	NN-V629MB
29		E110D4N30ZGP	OUTER PANEL	1	NN-V659FB
30	!	E63268960JP	TT MOTOR	1	
31		E21778000BP	PULLEY SHAFT WASHER	1	
32		E21315870GP	PULLEY SHAFT	1	
33		E30074L00GS	LOWER HINGE	1	
34		E01507550BP	OUTER PANEL WARNING LABEL	1	NN-V689WB NN-V659WB
34		E01507560BP	OUTER PANEL WARNING LABEL	1	NN-V659CB/MB/FB
35	!	E20554L00GS	COVER A	1	
36		XST4+W5V	SCREW	1	FOR COVER A
37		E200A4N50BP	OVEN CAVITY	1	NN-V689
37		E200A4N30BP	OVEN CAVITY	1	NN-V659 NN-V629
38		E64604N30BP	HEATER SUPPORT BRACKET	2	
39		E03594N30GP	GRILL LINK	1	
40	!	E630G8000BP	QUARTZ HEATER	2	
41		E40244N30BP	EXHAUST GUIDE	1	
42		E00064080BP	WARNING LABEL	1	
43		E11405840GP	STOPPER A	1	
44	!	E607S7050AP	STEAM SENSOR	1	NN-V689WB
45		E407F8010BP	SENSOR UNIT	1	NN-V689WB
46		E64504N50BP	SENSOR COVER B	1	NN-V689WB
47		E09250000BD	CUSHION RUBBER	1	NN-V689WB
48		E09020000AH	CUSHION RUBBER	1	

12. DOOR ASSEMBLY

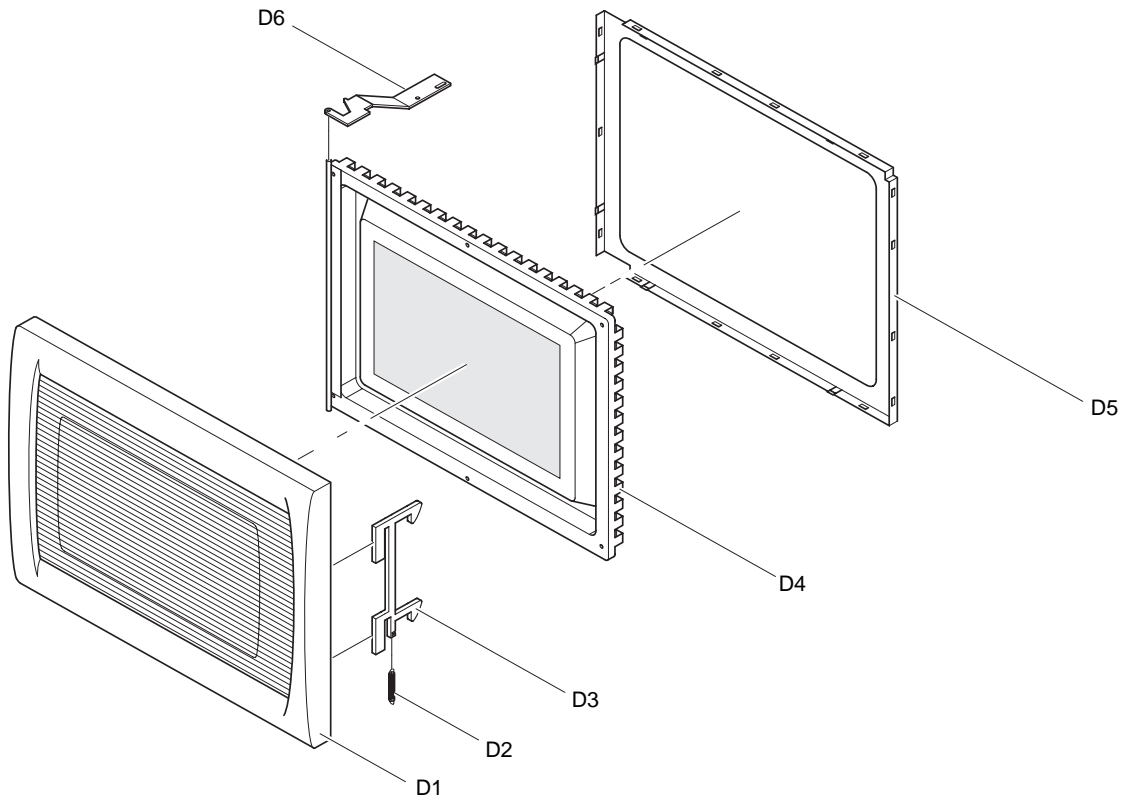

Ref. No.	Part No.	Part Name & Description	Pcs/Set	Remarks
D1	E302A4N30HBP	DOOR A SCREEN B ASSY	1	NN-V689WB NN-V659WB
D1	E302A4N30BP	DOOR A SCREEN B ASSY	1	NN-V659CB
D1	E302A4N30NBP	DOOR A SCREEN B ASSY	1	NN-V629MB
D1	E302A4N30ZBP	DOOR A SCREEN B ASSY	1	NN-V659FB
D2	E30214000AP	DOOR KEY SPRING	1	
D3	E30184L00GS	DOOR KEY A	1	
D4	!	E302K4N30BP	DOOR E UNIT	1
D5	E30854N30BP	DOOR C	1	
D6	E30064N30BP	UPPER HINGE	1	

NOTE: When ordering any door component also order door C as this part may become damaged during disassembly.

13. ESCUTCHEON BASE ASSEMBLY

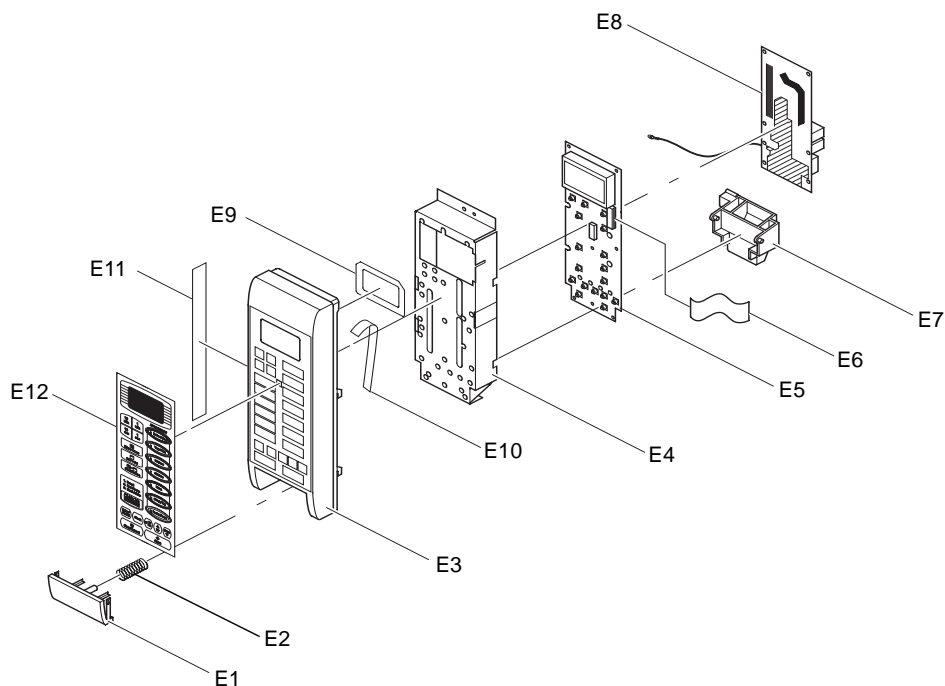

Ref. No.	Part No.	Part Name & Description	Pcs/Set	Remarks
E1	E80724L10HBP	DOOR OPENING BUTTON	1	NN-V689WB NN-V659WB
E1	E80724L10BP	DOOR OPENING BUTTON	1	NN-V659CB
E1	E80724L10NBP	DOOR OPENING BUTTON	1	NN-V629MB
E1	E80724L10ZBP	DOOR OPENING BUTTON	1	NN-V659FB
E2	E80378A0AG	DOOR OPENING BUTTON SPRING	1	
E3	E80344L10HBP	ESCUTCHEON BASE	1	NN-V689WB NN-V659WB
E3	E80344L10BP	ESCUTCHEON BASE	1	NN-V659CB
E3	E80344L10NBP	ESCUTCHEON BASE	1	NN-V629MB
E3	E80344L10ZBP	ESCUTCHEON BASE	1	NN-V659FB
E4	E81274L10BP	ESCUTCHEON BACK PLATE	1	
E5	! E603L4N50BP	DPC AU	1	NN-V689WB
E5	! E603L4N30BP	DPC AU	1	NN-V659WB NN-V659CB NN-V629MB NN-V659FB
E6	E66164L00GS	RIBBON CABLE	1	
E7	E82564L10BP	DOOR OPENING LEVER	1	
E8	! E603Y4N50BP	DPC DU	1	NN-V689WB
E8	! E603Y4L20BP	DPC DU	1	NN-V659WB NN-V659CB NN-V629MB NN-V659FB
E9	E83264L10BP	DISPLAY SHEET	1	
E10	! E90014N30BP	EARTH STRIP	1	NN-V629MB NOTE*
E11	E00074N30BP	NAME PLATE	1	NOTE*
E12	E83374N50HBP	ESCUTCHEON SHEET	1	NN-V689WB
E12	E83374N30HBP	ESCUTCHEON SHEET	1	NN-V659WB
E12	E83374N30BP	ESCUTCHEON SHEET	1	NN-V659CB
E12	E83374N30NBP	ESCUTCHEON SHEET	1	NN-V629MB
E12	E83374N30ZBP	ESCUTCHEON SHEET	1	NN-V659FB

NOTE *: Please order Escutcheon Base and Name Plate together.

NOTE *: When replacing the silver escutcheon sheet ensure it is earthed to the escutcheon back plate via the earth strip.

14. PACKING AND ACCESSORIES

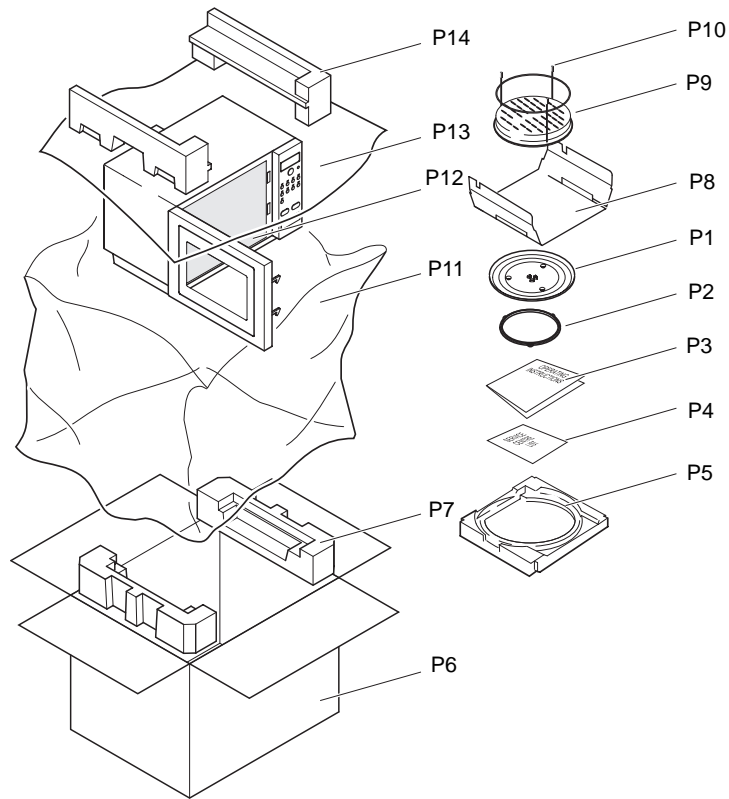

Ref. No.	Part No.	Part Name & Description	Pcs/Set	Remarks
P1	E06014N30BP	GLASS TRAY	1	
P2	E290D4N30BP	ROLLER RING	1	
P3	E00034N30BP	OPERATING INSTRUCTIONS	1	
P4	E01695750BP	SERVICE CENTER LIST	1	
P5	E01134N30BP	TRAY STYROL	1	
P6	E01024N50HBP	CARTON BOX	1	NN-V689WB
P6	E01024N30HBP	CARTON BOX	1	NN-V659WB
P6	E01024N30BP	CARTON BOX	1	NN-V659CB
P6	E01024N30NBP	CARTON BOX	1	NN-V629MB
P6	E01024N30ZBP	CARTON BOX	1	NN-V659FB
P7	E01054N30BP	LOWER FILLER	1	
P8	E01084N30BP	TRAY PACKING	1	
P9	E060V6520BP	WIRE RACK	1	
P10	E06435870SP	WIRE RACK FOOT	3	
P11	E01066750BP	VINYL COVER	1	
P12	E01076700BP	DOOR SHEET	1	
P13	E01926430GP	PROTECTOR SHEET	1	
P14	E01044N30BP	UPPER FILLER	1	

15. TRIM KIT PARTS LIST

Parts list for microwave oven trim kits

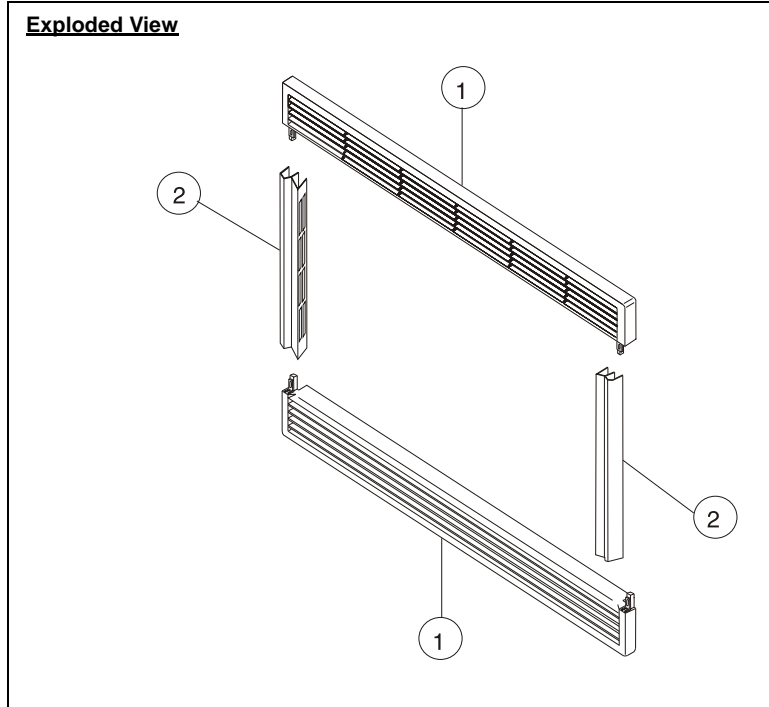

Trim Model No.	Top and Bottom Strip Ref No: 1	Pcs/Set	Side Strip Ref No: 2	Pcs/Set	Microwave Oven Model No.
NN-TKV69W	E1603A510HBP	2	E1601A510HBP	2	NN-V689WB NN-V659WB
NN-TKV69C	E1603A510BP	2	E1601A510BP	2	NN-V659CB
NN-TKV69M	E1603A510NBP	2	E1601A510NBP	2	NN-V629MB
NN-TKV69F	E1603A510ZBP	2	E1601A510ZBP	2	NN-V659FB
TRIMKIT ASSY INSTRUCTION			E0003A4N30BP		

16. DIGITAL PROGRAMMER CIRCUIT

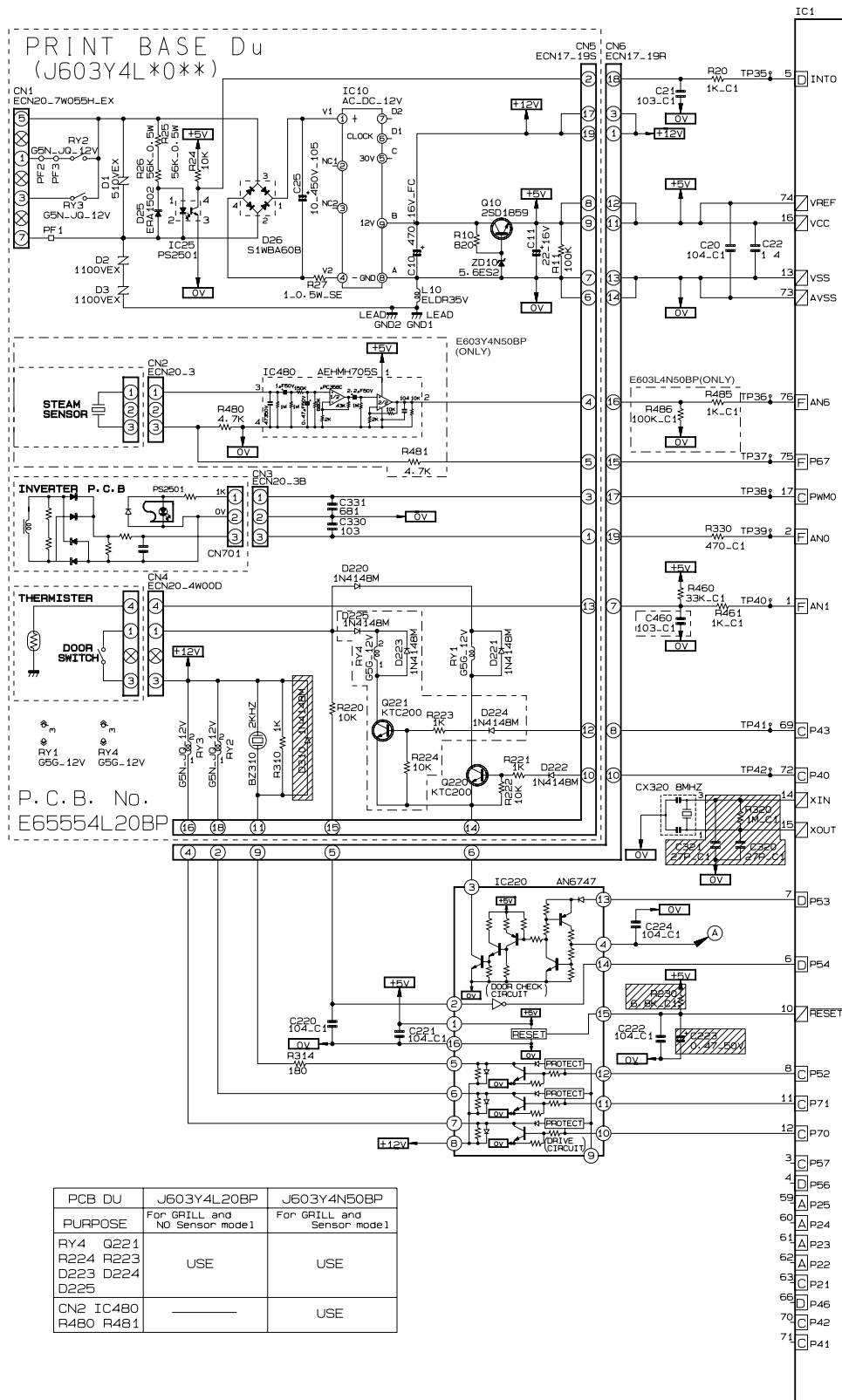

M38C34***

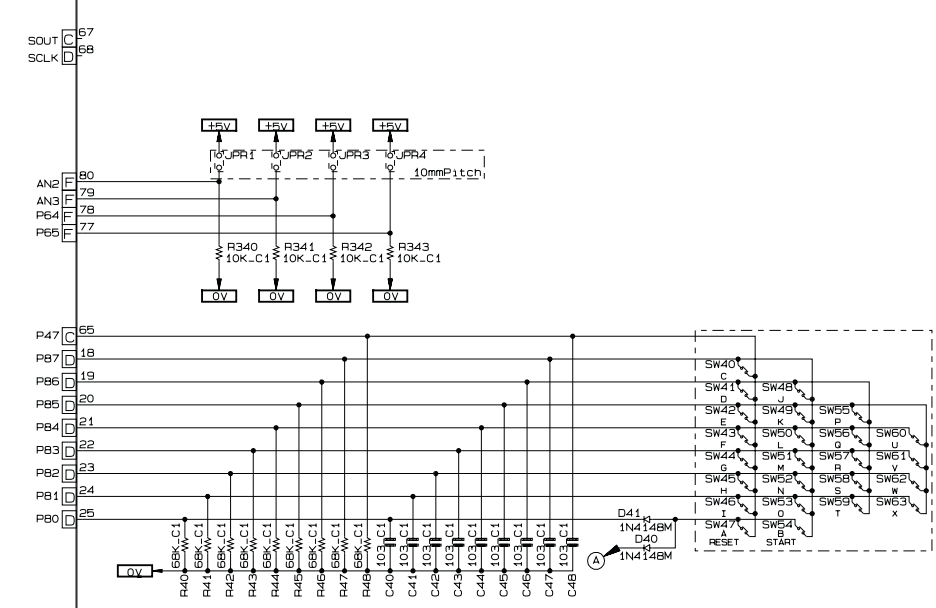

NC

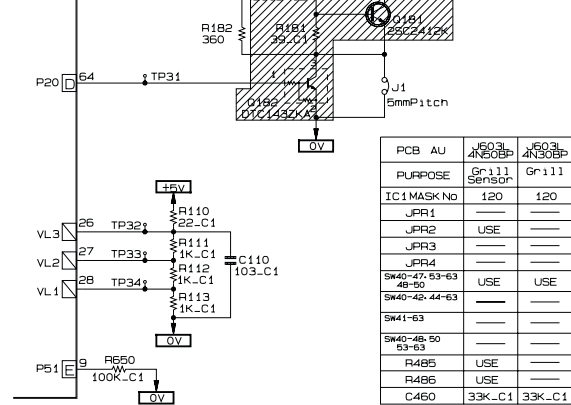
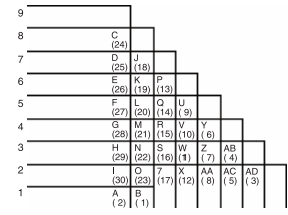
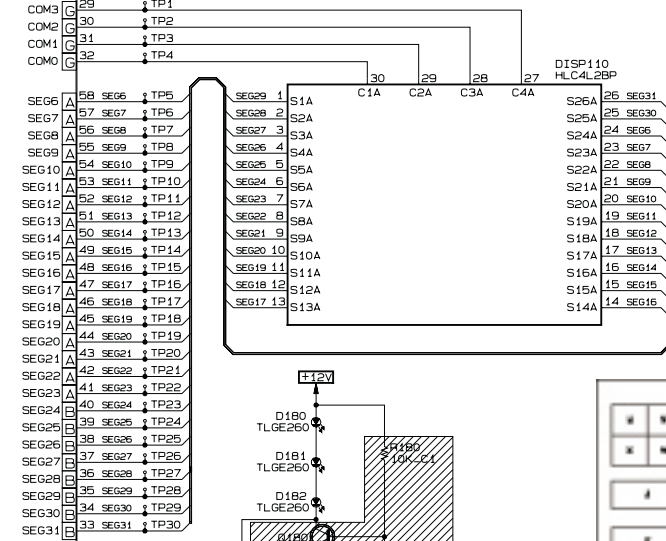

PCB AU	Gr111 Sensor	Gr111	Gr111
PUFPOSE	IC1 MASK No	120	120
JPR1			
JPR2	USE		
JPR3			
JPR4			
Sw40-47, 53-63, 48-50	USE	USE	
Sw40-42, 44-63			
Sw41-63			
Sw40-46, 50, 53-63			
R465	USE		
R466	USE		
C460	33K_C1	33K_C1	

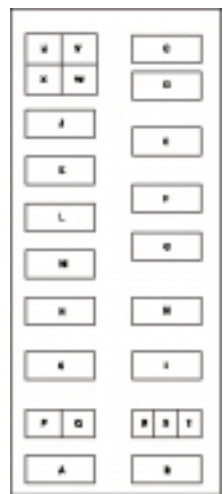

	NN-V689 S-4N58P E603L4N50BP	NN-V659 S-4N38P E603L4N30BP
B (1)	START	START
A (2)	RESET	RESET
AD (3)		
AD (4)		
AC (5)		
Y (6)		
Z (7)		
AA (8)		
U (9)	10MIN	10MIN
V (10)	1MIN	1MIN
W (11)	1SEC	1SEC
X (12)	10SEC	10SEC
P (13)	STAND	STAND
Q (14)	CLOCK	CLOCK
R (15)	CONVERSION	CONVERSION
S (16)	UP/MORE	UP
T (17)	DOWN/LESS	DOWN
J (18)	POWER	POWER
K (19)	GRILL	GRILL
L (20)	COMBI	COMBI
M (21)		
N (22)		
O (23)	AUTO (DEF)	AUTO (DEF)
C (24)	AUTO	AUTO
D (25)	AUTO	AUTO
E (26)	AUTO	AUTO
F (27)	AUTO	AUTO
G (28)	AUTO	AUTO
H (29)	AUTO	AUTO
I (30)	AUTO	AUTO

17. DIGITAL PROGRAMMER CIRCUIT - PARTS LIST

DPC AU - E603L4N50BP (NN-V689WB)

Ref. No.	Part No.	Description	Qty	Remarks
CN6	AEEM19FESVKN	19PIN CONNECTOR	1	
DISP	AEDDHLC4L2BP	LCD	1	
IC220	AN6747B	CUSTOM IC	1	
D180-D182	AESQTLGE260T	GREEN LED	3	
CX320	EF0MC8004T4	CERAMIC RESONATOR	1	
SW40-42	EVQ11L05R	PUSH SWITCH	22	
SW44-48				
SW51				
SW53-63				
R182	ERDS2TJ361T	RESISTOR	1	360Ω
R314	ERDS2TJ181T	RESISTOR	1	180Ω
C22	AECF50F104Z	CAPACITOR	1	100 nF
D40-41	AESS1N4148M	DIODE	2	
IC1	AEIC8C34A120	IC1	1	
"C21,C40-C48"	AECU1F103Z50	CHIP CAPACITOR	11	10 nF
"C110,C460"				
"C20,C220-C222"	AECU1F104Z25	CHIP CAPACITOR	5	100nF
C224				
"R20,R111-R113"	ERJ3GSYJ102V	CHIP RESISTOR	6	1KΩ
R461				
R340-R343	ERJ3GSYJ103V	CHIP RESISTOR	4	10KΩ
R650	ERJ3GSY104V	CHIP RESISTOR	1	100KΩ
R110	ERJ3GSYJ220V	CHIP RESISTOR	1	22Ω
R460	ERJ3GSYJ333V	CHIP RESISTOR	1	33KΩ
R330	ERJ3GSYJ471V	CHIP RESISTOR	1	470Ω
R40-R48	ERJ3GSYJ683V	CHIP RESISTOR	9	68KΩ

DPC DU - E603Y4N50BP (NN-V689WB)

Ref. No.	Part No.	Description	Qty	Remarks
CN5	AEEM19FEBVKN	19 PIN CONNECTOR	1	
CN1	AEEMMD05507W	7 PIN CONNECTOR	1	
"RY1,RY4"	AEGG5G1A12	RELAY	2	12V
"RY2,RY3"	AEBGG5N1A12	RELAY	2	12V
D1	ERZV10D511CS	VARISTOR	1	
"D2,D3"	ERZV10D112C1	VARISTOR	2	
1C25	AEICP25011HL	PHOTOCOUPLER	1	
D26	AESTS1WBA60B	DIODE BRIDGE	1	
BZ310	EFBAH20C001	BUZZER	1	2KHz
IC10	ETXMJ197X1BG	SWITCH POWER SUPPLY	1	
CN3	AEEMMF00703B	3 PIN CONNECTOR	1	
CN4	AEEMMF00D04W	4 PIN CONNECTOR	1	
L10	EXCELD35V	INDUCTOR	1	
"Q220,Q221"	AESCKTC200	NPN TRANSISTOR	2	
C11	ECEA1CKA220B	CAPACITOR	1	22μF 16V
C25	ECA2WHG100E	CAPACITOR	1	10μF 450V
C10	EEUFC1C471B	CAPACITOR	1	470μF 16V
R27	ERX12SJ1R0E	RESISTOR	1	1Ω 1/4W
Q10	2SD1859TV2	POWER TRANSISTOR	1	
"R220,R22"	ERDS2TJ103T	RESISTOR	4	10KΩ 10%
R24				
C330	ECBT1E103ZF5	CAPACITOR	1	10nF
C331	ECBT1H681KB5	CAPACITOR	1	68pF
R11	ERDSTJ104T	RESISTOR	1	100KΩ 5%
"R221,R223,R310"	ERDSTJ102T	RESISTOR	3	1KΩ 5%
R10	ERDS2TJ821T	RESISTOR	1	820Ω
D220-D225	AESS1N4148M	DIODE	6	
D25	AEDNERA1502	DIODE	1	
ZD10	AEDZ5R6ES2T1	ZENER DIODE	1	
"R26,R25"	ERDS1FJ563T	RESISTOR	2	56KΩ 1/2W
CN2	AEEMMF00703W	3 PIN CONNECTOR	1	

DPC AU - E603L4N30BP (NN-V659) (NN-V629)

Ref. No.	Part No.	Description	Qty	Remarks
CN6	AEEM19FESVKN	19PIN CONNECTOR	3	
DISP	AEDDHLCL4L2BP	LCD	1	
IC220	AN6747B	CUSTOM IC	1	
D180-D182	AESQTLGE260T	GREEN LED	3	
CX320	EF0MC8004T4	CERAMIC RESONATOR	1	
SW40-42	EVQ11L05R	PUSH SWITCH	20	
SW44-48				
SW51				
SW53-63				
R182	ERDS2TJ361T	RESISTOR	1	360Ω
R314	ERDS2TJ181T	RESISTOR	1	180Ω
C22	AECF50F104Z	CAPACITOR	1	100 nF
D40-41	AESS1N4148M	DIODE	2	
IC1	AEIC8C34A120	IC1	1	
"C21,C40-C48"	AECU1F103Z50	CHIP CAPACITOR	11	10 nF
"C110,C460"				
"C20,C220-C222"	AECU1F104Z25	CHIP CAPACITOR	5	100nF
C224				
"R20,R111-R113"	ERJ3GSYJ102V	CHIP RESISTOR	5	1KΩ
R461				
R340-R343	ERJ3GSYJ103V	CHIP RESISTOR	4	10KΩ
R650	ERJ3GSY104V	CHIP RESISTOR	1	100KΩ
R110	ERJ3GSYJ220V	CHIP RESISTOR	1	22Ω
R460	ERJ3GSYJ333V	CHIP RESISTOR	1	33KΩ
R330	ERJ3GSYJ471V	CHIP RESISTOR	1	470Ω
R40-R48	ERJ3GSYJ683V	CHIP RESISTOR	9	68KΩ

DPC DU - E603Y4L20BP (NN-V659) (NN-V629)

Ref. No.	Part No.	Description	Qty	Remarks
CN5	AEEM19FEBVKN	19 PIN CONNECTOR	1	
CN1	AEEMMD05507W	7 PIN CONNECTOR	1	
"RY1,RY4"	AEGG5G1A12	RELAY	2	12V
"RY2,RY3"	AEBGG5N1A12	RELAY	2	12V
D1	ERZV10D511CS	VARISTOR	1	
"D2,D3"	ERZV10D112C1	VARISTOR	2	
1C25	AEICP25011HL	PHOTOCOUPLER	1	
D26	AESTS1WBA60B	DIODE BRIDGE	1	
BZ310	EFBAH20C001	BUZZER	1	2KHz
IC10	ETXMJ197X1BG	SWITCH POWER SUPPLY	1	
CN3	AEEMMF00703B	3 PIN CONNECTOR	1	
CN4	AEEMMF00D04W	4 PIN CONNECTOR	1	
L10	EXCELDLR35V	INDUCTOR	1	
"Q220,Q221"	AESCKTC200	NPN TRANSISTOR	1	
C11	ECEA1CKA220B	CAPACITOR	1	22μF 16V
C25	ECA2WHG100E	CAPACITOR	1	10μF 450V
C10	EEUFC1C471B	CAPACITOR	1	470μF 16V
R27	ERX12SJ1R0E	RESISTOR	1	1Ω 1/4W
Q10	2SD1859TV2	POWER TRANSISTOR	1	
"R220,R22"	ERDS2TJ103T	RESISTOR	2	10KΩ 10%
R24				
C330	ECBT1E103ZF5	CAPACITOR	1	10nF
C331	ECBT1H681KB5	CAPACITOR	1	68pF
R11	ERDS2TJ104T	RESISTOR	1	100KΩ 5%
"R221,R223,R310"	ERDS2TJ102T	RESISTOR	3	1KΩ 5%
R10	ERDS2TJ821T	RESISTOR	1	820Ω
D220-D225	AESS1N4148M	DIODE	6	
D25	AEDNERA1502	DIODE	1	
ZD10	AEDZ5R6ES2T1	ZENER DIODE	1	
"R26,R25"	ERDS1FJ563T	RESISTOR	2	56KΩ 1/2W

E607X4N30BP - Noise Filter Assembly

Ref. No.	Part No.	Description	Qty	Remarks
R1	ERG1SJ753P	RESISTOR	1	75KΩ 1W
C1&C2	QETJ5225KRP2CE	CAPACITOR	2	2.2μf
C3&C4	ECKMNA472ME	CAPACITOR	2	4700pF 250V AC
L1	SC-08-E203A	INDUCTOR	1	2.4mH
F1	E62316010BP	FUSE HOLDER	2	

NOTES:

NOTES:

SM **K** **PEN**
S - 4N30BP
S - 4N50BP
Printed in the UK